

# User manual

## ADA-I1040

### RS-232 to RS-485 / RS-422 Converter



## Contents

1. GENERAL INFORMATION.....	3
1.1. WARRANTED INFORMATION.....	3
1.2. GENERAL CONDITIONS FOR SAFE USE.....	3
1.3. CE LABEL.....	3
1.4. ENVIRONMENTAL PROTECTION.....	3
1.5. SERVICE AND MAINTENANCE.....	3
1.6. PACK CONTENTS.....	3
2. PRODUCT INFORMATION.....	3
2.1. PROPERTIES.....	3
2.2. DESCRIPTION.....	4
2.3. CONVERSION OF TX AND RX SIGNALS.....	4
2.4. ISOLATION.....	5
3. INSTALLATION.....	5
3.1. CONNECTION TO RS232 PORT OF PC.....	5
3.2. CONNECTION TO RS485 / RS422 BUS.....	6
3.2.1. CONNECTION TO 4-WIRE RS422 BUS.....	6
3.2.2. CONNECTION TO 4-WIRE RS485(4W) BUS.....	7
3.2.3. CONNECTION TO 2-WIRE RS485(2W) BUS.....	7
3.2.4. EXTENSION OF RS232 COMPUTER PORT.....	8
3.3. LINE TERMINATION.....	8
3.4. POWER SUPPLY CONNECTION.....	8
4. CONFIGURATION.....	8
4.1. DESCRIPTION OF DIP SWITCH SW2.....	8
4.1.1. OPERATING MODE.....	9
4.1.2. SIGNALS (RTS-CTS, DTR-DSR) LOOPING OF RS232 INTERFACE.....	9
4.2. DESCRIPTION OF DIP SWITCH SW1.....	9
4.3. FACTORY DEFAULT.....	10
5. ACTIVATION.....	10
6. DESCRIPTION OF PINS D-SUB9 FEMALE CONNECTOR OF RS232 INTERFACE.....	10
7. VERSIONS.....	10
8. SPECIFICATION.....	11

## 1. GENERAL INFORMATION

Thank you for your purchase of **CEL-MAR Company** product. This product has been completely tested and is covered by a two year warranty on parts and operation from date of sale.

If any questions or problems arise during installation or use of this product, please do not hesitate to contact Technical Support at +4841 362-12-46 or e-mail [support@cel-mar.pl](mailto:support@cel-mar.pl).

### 1.1. WARRANTED INFORMATION

**ADA-I1040** converter is covered by a two year warranty from date of sale. In case of being damaged it will be repair or the damaged component will be replace. The warranty does not cover damage caused from improper use, materials consumption or any unauthorized changes. If the product does not function (is damaged), or not operate in accordance with the instructions, will be repaired or replaced.

All warranty and no warranty repairs must be returned with paid transport and insuring to the **CEL-MAR Company**.

**CEL-MAR Company** under no circumstances won't be responsible for ensuing damage from improper using the product or as a result of random causes: the lightning discharge, the flood, the fire and the like.

**CEL-MAR Company** is not held responsible for damages and loss including: loss of profits, loss of data, pecuniary losses ensuing from using or the impossibility of using this product.

In specific cases **CEL-MAR Company** discontinue all warranties and in particular do not follow the user manual and do not accept terms of warranty by the user.

### 1.2. GENERAL CONDITIONS FOR SAFE USE

The device should be installed in a safe and stable places (eg, electroinstallation cabinet), the powering cable should be arranged so as not to be exposed to trampling, attaching, or pulling out of the circuit.

Do not put device on the wet surface.

Do not connect devices for nondescript powering sources,

Do not damage or crush powering wires.

Do not make connection with wet hands.

Do not adapt, open or make holes in casings of the device!

Do not immerse device in water or no other liquid.

Do not put the fire opened on device sources: candles, an oil lamps and the like.

Complete disable from the supply network is only after disconnecting the power supply circuit voltage.

Do not carry out the assembly or dis-assembly of the device if it is enabled. This may result to short circuit and damage the device.

The device can not be used for applications that determine human life and health (eg. Medical).

### 1.3. CE LABEL



CE symbol on organizing the company CEL-MAR a conformity of the device to the Directive: **EMC 2014/30/WE** (Electromagnetic Compatibility Directive).

Declaration of Conformity is delivered with purchased converter.

### 1.4. ENVIRONMENTAL PROTECTION



This label on the device inform about putting expended device with other waste materials. Device should send to the recycling. (In accordance with the act about the Electronic Appliance Expended from day 29 of July 2005)

### 1.5. SERVICE AND MAINTENANCE

ADA-I1040 does not require the servicing and maintenance.

Technical support is available at number +48 41 362-12-46 in 8.00-16.00, from Monday to Friday or e-mail [support@cel-mar.pl](mailto:support@cel-mar.pl).

### 1.6. PACK CONTENTS

ADA-I1040 converter, user manual, CE declaration.

## 2. PRODUCT INFORMATION

### 2.1. PROPERTIES

- Functioning on RS485 2-wire or 4-wire network in Point-to-Point and Multi-Point mode,
- Functioning on RS422 2-wire or 4-wire network in Point-to-Point,
- Polarization of RS485/RS422 bus, MASTER or SLAVE type,
- Conversion TX, RX signal to RS485/RS422 standard,
- Possibility of connection up to 32 devices on RS485 network,
- Baud rate up to 230,4 kbps,
- Transparent for all protocols: MODBUS, DNP and other,
- Any format of byte, defined with the specification of RS232 interface,
- Power supply 10 - 30 VDC stable min. 1W,
- Possibility of powering from two independent sources,
- 3kV= optoisolation in signal channel between RS232 and RS485/RS422 interface,
- 1kV= or 3kV= galvanic isolation between RS232 interface and power supply,
- Implemented short circuit protection and over-voltage protection on RS485/422 network,
- Connection RS485/RS422 interface via screw terminal block,
- Connection RS232 interface via DB-9 female connector,
- Interface casing,
- Dimensions (W x D x H) 84mm x 23mm x 59mm.

**2.2. DESCRIPTION**

Many devices as PLC controllers, sensors, measuring transducer, cash registers, electronic weight are equipped with RS232 communication port. The standard has limitation of the lengths cable (the distance 15m which transmissions correctly). Using the RS485/422 standard to the data transmission is solving this problem. The RS485/RS422 standard lets to connect devices dismissed about 1200m.

ADA-I1040 converts RS232 to RS485/RS422 without interference in data format. This converter does not require powering from RS232 port, supports the asynchronous baud rate up to 230.4 kbps through four or two-pair of twisted-pair cable of RS485/RS422 interface.

Converter has female DB-9F connector for connection of RS232 interface, screw terminal block for connection of RS485/422 bus and power supply, and also JACK socket for power supply additionally. This DB-9F connector has made as DCE, what let connect the converter to other RS-232 devices, by the use RS232 extender cable (typical modem connection cable) without crossover Tx with Rx, RTS with CTS, DTR with DSR.

Converter use for functioning Rx, Tx, RTS signals and GND (inserted by the DB-9F socket). Galvanic isolation and optoisolation in signals channel separate RS232 interface from RS485/RS422 and protect device connected to RS232 port from over-voltage on RS485/RS422 Bus and power circuit. Over-voltage protection on each RS485/RS422 line was made on base of over-voltage led and fuses.

ADA-I1040 should be power from stabilized power supply unit with a voltage ranging from 10 - 30 VDC and minimum power 1W. Converter can be powered from two independent sources, one connected to terminal block second to the JACK 1,5/3,5 connector.

**2.3. CONVERSION OF TX AND RX SIGNALS**

Conversion of RS232 to RS485/RS422 (and inversely) are signals: Tx and RX of RS232 interface.

The flow data control on RS485 bus in a converter is automatic.

It is possible to connect 32 devices by the use of ADA-I1040, operating in modes as:

- half duplex (inquiry/response) on 2 or 4 wires multipoint bus,
- full duplex on 4-wire bus

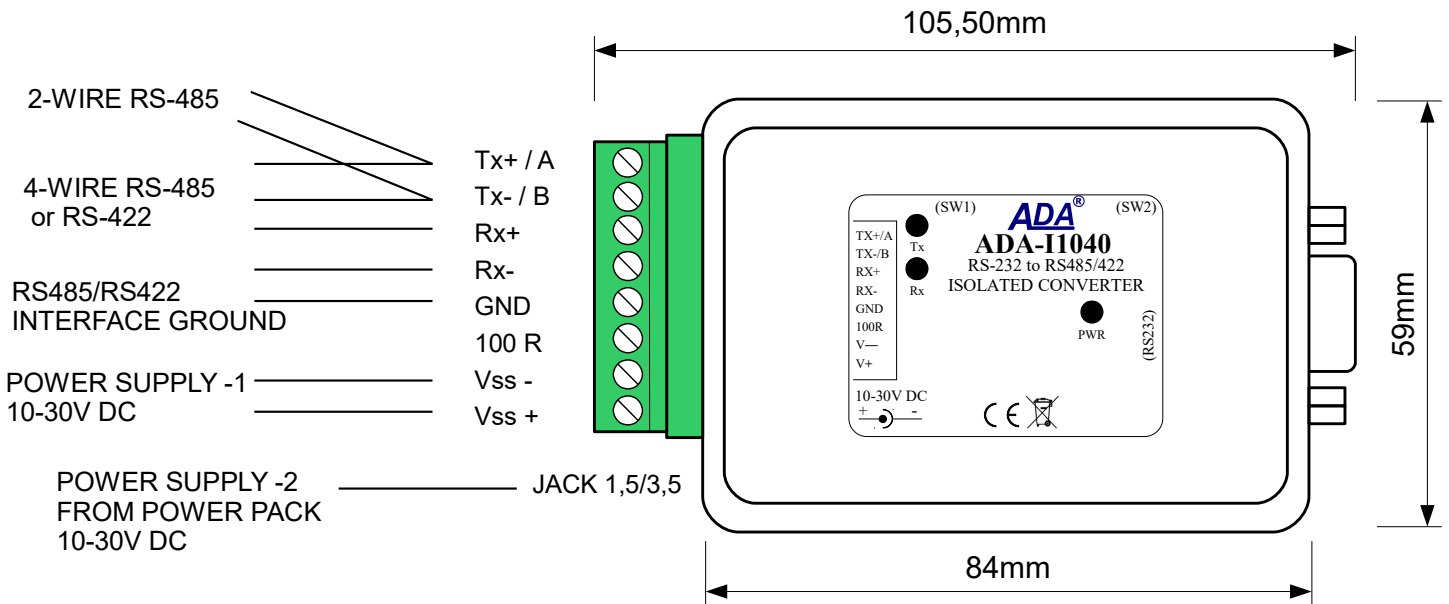
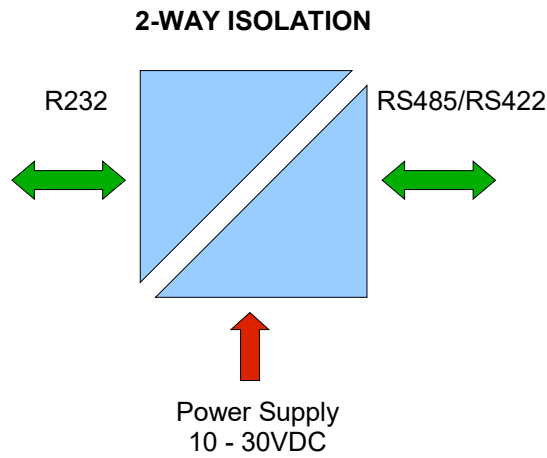

Fig. 1. View

**2.4. ISOLATION**

Converter ADA-I1040 has 2-way or 3-way galvanic isolation, described in section *VERSIONS*.



**Fig. 2. Insulation structure**

**3. INSTALLATION**

This chapter will show how to connect ADA-I1040 to RS485/RS422, RS232 bus and power supply.

In the purpose of minimization of disruptions from environment is being recommended to:

- apply multipair type shielded cables, which shield can be connected to the earthing on one end of the cable,
- arrange signal cables in the distance not shorter than 25 cm from powering cables,
- apply cable of adequate cross-section due to voltage drops for converter powering,
- use a Interference suppression filters to the power supply converters, installed in one object,
- not supply converter from power circuit device that generates large impulse interference such as transmitters, contactors,

**3.1. CONNECTION TO RS232 PORT OF PC**

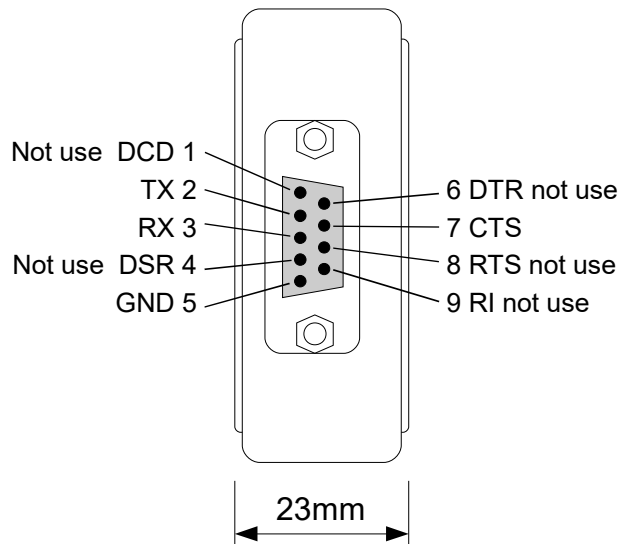

**Fig. 3. Signal configuration of RS-232 interface in converter DB-9F connector (female)**

Connection should be done in use of shielded cable (RS232 extender) ended DB-9M male plug, max. lengths up to 15m. It is recommended to connect shield to ground in one side (PC).

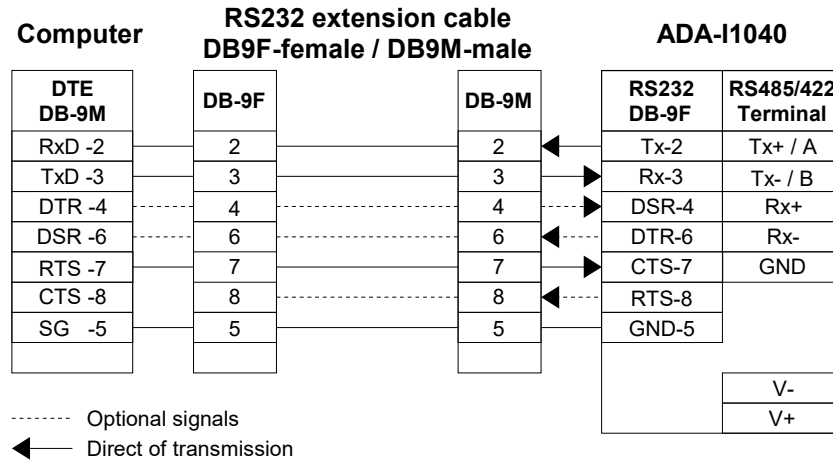

Fig. 4. Connection to RS232 computer port

### 3.2. CONNECTION TO RS485 / RS422 BUS

RS485/RS422 interface of ADA-I1040 converter is available on Tx+/A, Tx-/B, Rx+, Rx- screw terminal block. ADA-I1040 can operate on RS485 and RS422 bus. This two networks should have appropriate wiring.

In the purpose of minimization of disruptions from environment is being recommended to:

- apply multipair type shielded cables, which shield can be connected to the earthing on one end of the cable,
- arrange signal cables in the distance not shorter than 25 cm from powering cables,

#### 3.2.1. CONNECTION TO 4-WIRE RS422 BUS

After connection of devices according to diagram below the converter should set to functioning on RS422 bus.

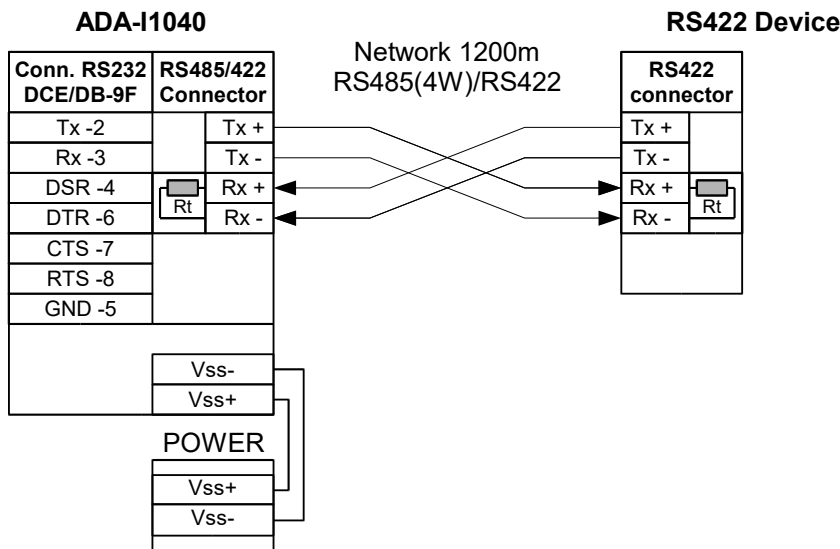

Fig. 5. Example connection of RS422 devices

**3.2.2. CONNECTION TO 4-WIRE RS485(4W) BUS**

After connection of devices according to diagram below the converter should set to functioning on RS485 bus.

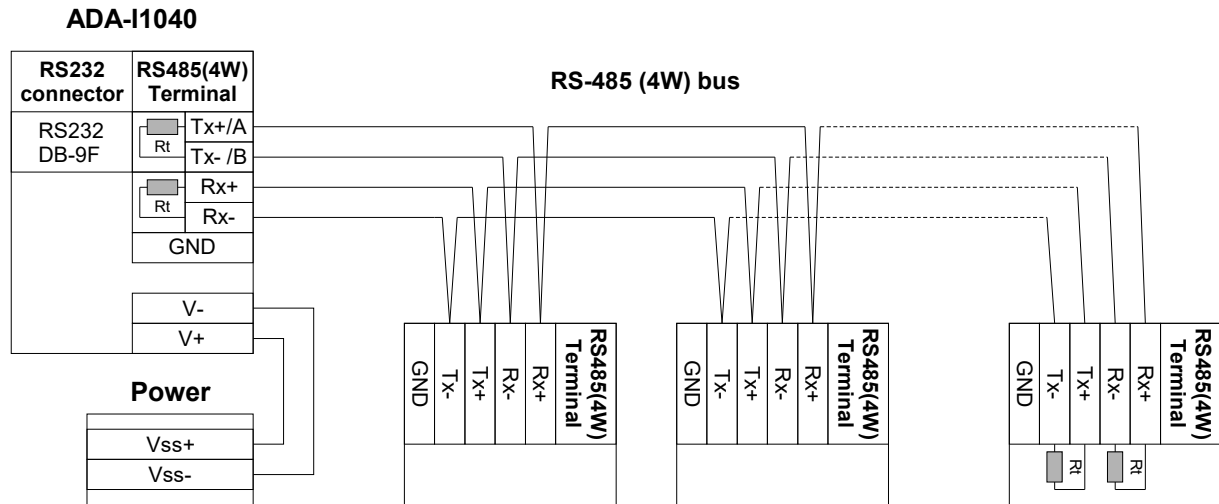

Fig. 6. Example connection of RS485(4W) devices

**3.2.3. CONNECTION TO 2-WIRE RS485(2W) BUS**

After connection of devices according to diagram below the converter should set to functioning on RS485 bus.

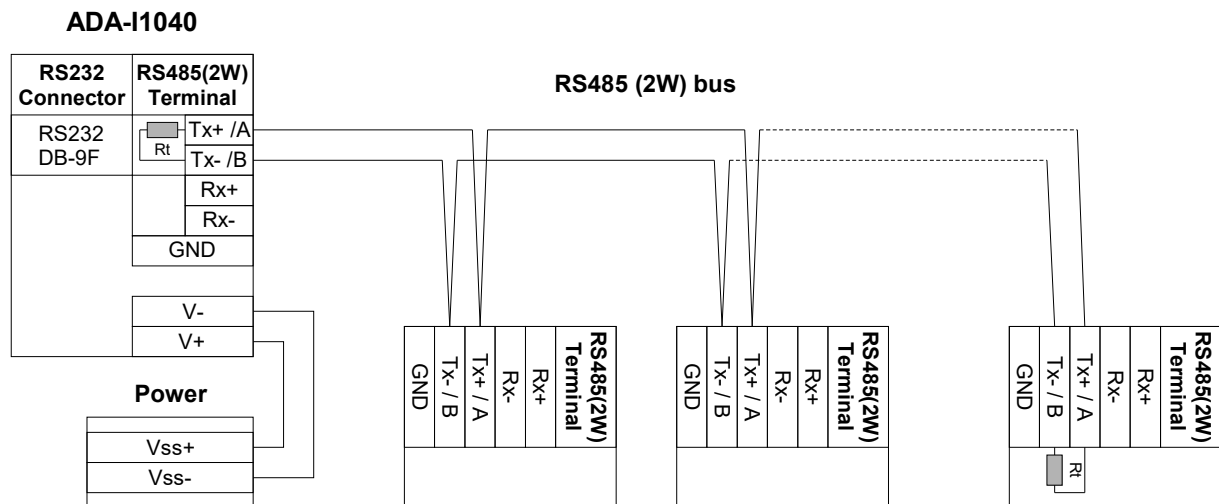
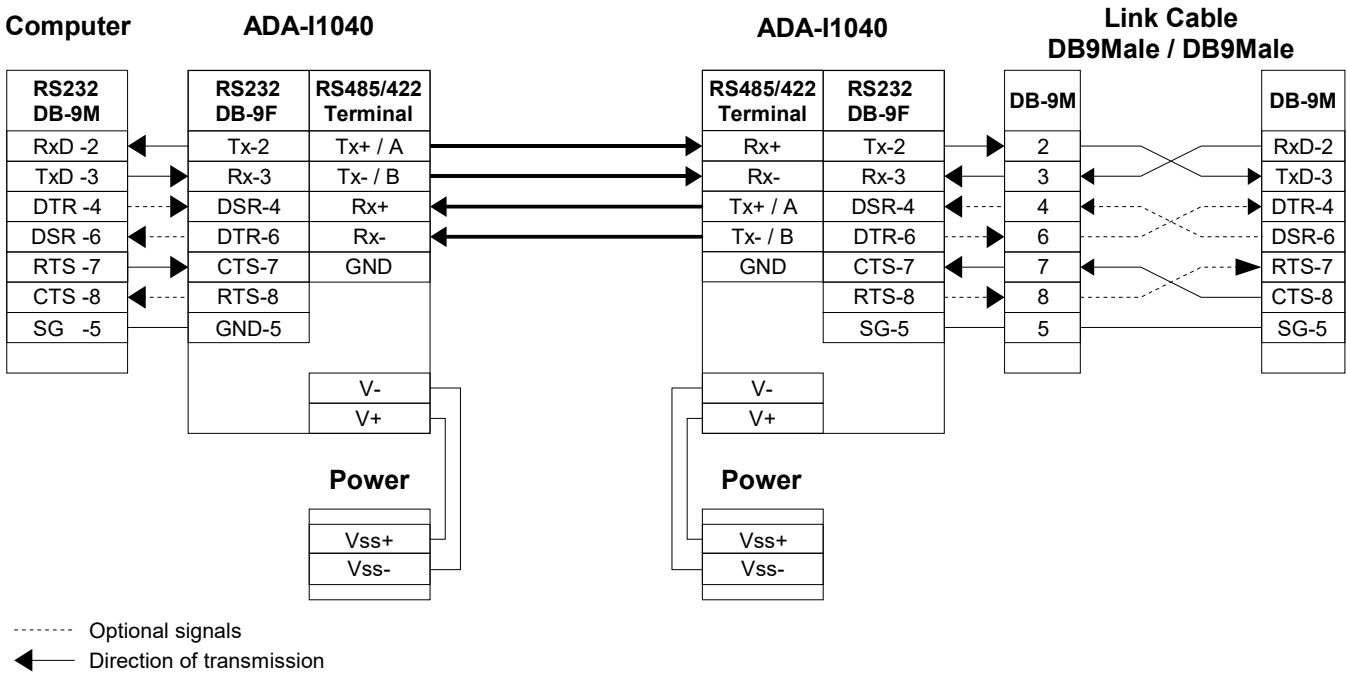

Fig.7. Example connection of RS485(2W) devices

**3.2.4. EXTENSION OF RS232 COMPUTER PORT**

After connection of devices according to diagram below the converter should set to functioning on RS422 bus.



**Fig. 8. Extender type connection of RS232 computer port**

**3.3. LINE TERMINATION**

Use the Line Termination (terminator)  $R_t = 120$  ohms will reduce electrical reflection in data line at high baud rate. It is not needed below 9600Bd. The Line Termination resistor should be use if the distance is over 1000m @ 9600Bd or 700m @ 19200Bd transmission. The Line Terminations (terminators)  $R_t$  in ADA-I1040 are connected to RS485/RS422 bus by using the SW1 switch.

Example connection of  $R_t$  are shown on fig 5,6 & 7.

**3.4. POWER SUPPLY CONNECTION**

To connect power supply to converter, should be used DC power supplies (regulated) output voltage from 10 V= to 30V=, min. nominal power 1W, e.g. ZS-12/250. Power cable from DC power supplies to device can not be longer than 3m. For powering the converter, by the use of two wires via terminal block, follow the points:

1. Disconnect screw terminal block (8-pin) from converter,
2. Connect positive (+) end of DC power supplies to Vss+ and negative (-) end to Vss- on terminal block,
3. Connect screw terminal block (8-pin) to converter,
4. Power ON the power supplies.

The converter can be feed from the pin power pack connecting the JACK 1,5/3,5 plug to the socket in the converter (see Fig. 1). It is possible to connect two different sources of converter feeding e.g. the stabilized power pack with voltage 10-30VDC and the accumulators battery of 12VDC or 24VDC.

Converter has protection against power supply reverse connection and if after connection power supply on front panel will not lighting green led PWR, should be checked the correctness connection of power supply.

**4. CONFIGURATION**

The 8-position Dip switch SW2 is use for setting of operating mode and looping of signals: RTS – CTS, DTR – DSR of RS232 interface and the 4-position switch SW1 is use for:

- connection of Line Terminations (terminators)  $R_t = 120$  W to terminals: [Tx+/A] & [Tx-/B], [Rx+] & [Rx-],
- setting of operation in ECHO mode.

**4.1. DESCRIPTION OF DIP SWITCH SW2**

The SW2 Dip switch on ADA-I1040 is used to set:

- operation mode in RS422 or RS485,
- signals looping of RTS-CTS, DTR-DSR,

The SW2 Dip switch is located on side surface of converter. All possible setting of Dip switch are shown in tables below (1 & 2). If you have any question please contact with Technical Department: [support@cel-mar.pl](mailto:support@cel-mar.pl)



#### 4.1.1. OPERATING MODE

Table 1. Setting of operating mode RS422 or RS485.

SW2-1	SW2-2	Description	Operating Mode
ON	ON	RS-485 bus	2-wire & 4-wire RS485 bus half duplex or full duplex.
OFF	OFF	RS-422 Bus	4-wire RS422 bus. full duplex or half duplex

#### 4.1.2. SIGNALS (RTS-CTS, DTR-DSR) LOOPING OF RS232 INTERFACE

Table 2.

SW2	Description of function position DIP SW2
SW2-3	ON – signals looping of RTS with CTS enable OFF – signals looping of RTS with CTS disable
SW2-4	ON – signals looping of DTR with DSR enable OFF – signals looping of DTR with DSR disable

#### ATTENTION!

**DCD signal is permanently connect with DSR in converter.**  
Setting the SW2 during data transmission can cause lost data.

#### 4.2. DESCRIPTION OF DIP SWITCH SW1

Six sections of micro switch SW1 on ADA-I1040 is used to set:

- connection of Line Terminations (terminators) to terminals: [Tx+/A] & [Tx-/B], [Rx+] & [Rx-],
- setting of operation in ECHO mode,
- connection of polarization RS485 interface MASTER / SLAVE type to Tx+/A i Tx-/B terminals.

The SW1 micro switch is located on side surface of converter.

Table 3.

SW1	Description of function position DIP SW1
1	ON – enable terminator between Rx+, Rx- terminals OFF – disable terminator between Rx+, Rx- terminals
2	ON – enable terminator between Tx+/A, Tx-/B terminals OFF – disable terminator between Tx+/A, Tx-/B terminals
3	ON – looping of B signal OFF – not looping of B signal
4	ON – looping of A signal OFF – not looping of A signal
5	ON – enable polarization of RS485 bus MASTER type to Tx+/ A terminal. OFF – enable polarization of RS485 bus SLAVE type to Tx+/ A terminal.
6	ON – enable polarization of RS485 bus MASTER type to Tx+/ B terminal. OFF – enable polarization of RS485 bus SLAVE type to Tx+/ B terminal.

#### ATTENTION !

**Should be ON sections 3 and 4 of SW1 micro switch to set ECHO operating mode. Setting of only one section will not switch converter in ECHO mode, but can cause errors during data transmission.**

**Enable/disable polarization of RS485 bus MASTER type is only in case of ON/OFF both sections of micro switch SW1-5 & SW1-6.**

### 4.3. FACTORY DEFAULT

The default setting of ADA-I1040 is:

1. RS-485bus, automatic data flow control,
2. RTS-CTS looped.
3. DTR-DSR-DCD looped.
4. Terminators not connected to terminals.
5. Disable ECHO operation mode.
6. Polarization of RS485 bus SLAVE type.

#### SW2 micro switch

Section 1	Section 2	Section3	Section 4
ON	ON	ON	ON

#### SW1 micro switch

Section 1	Section 2	Section 3	Section 4	Section 5	Section 6
OFF	OFF	OFF	OFF	OFF	OFF

### 5. ACTIVATION

After properly connection and setting, according to section above the ADA-I1040 can be power ON. Once activated the green LED PWR on front panel of module should illuminate. If after connection power supply the LED will not lighting, check the correctness of connecting power supply. When data is present LEDs should blink. A summary table of LED indications is listed below:

LED	Description
PWR	Signalization of Power Supply
RX	Signalization of data receiving from by ADA- I1040 from RS485/RS422.
TX	Signalization of data transmission from ADA-I1040 through RS485/RS422

#### ATTENTION !!!

AT SPEEDS ABOVE 38.400BPS TX AND RX LED WILL BE LESS LIGHT, DURING DATA TRANSMISSION.

### 6. DESCRIPTION OF PINS D-SUB9 FEMALE CONNECTOR OF RS232 INTERFACE

Pin	Signals	Description	ADA-I1040
1	(DCD)	Data Carrier Detected	Connected with DSR
2	(TX)	Transmit Data	Transmitter
3	(RX)	Receive Data	Receiver
4	(DSR)	Data Set Ready	Can be connected with DTR by use of SW2
5	(SG)	Signal Ground	GND
6	(DTR)	Data Terminal Ready	Can be connected with DSR by use of SW2
7	(CTS)	Clear to Send Data	Can be connected with RTS by use of SW2
8	(RTS)	Request to Send Data	Can be connected with CTS by use of SW2
9	(RI)	Ring Indicator	Not connected

### 7. VERSIONS

ADA- I1040 -  -

#### Electronic versions:

Basic,  
Special,

1  
2

#### Galvanic isolation:

1kV=  
3kV=

2  
3

Order example:

Product Symbol: **ADA-I1040-1-2**

1 – basic version of electronic,

2 - galvanic isolation 1kV=,

## 8. SPECIFICATION

TECHNICAL DATA		
Transmission Parameters		
Interface	RS-232	RS-485/RS-422
Connector	DSUB-9 Female	Screw terminal block - max. Ø 2,5mm <sup>2</sup>
Max. Line length	15 m	1200 m
Max. number of connected device	1	32 / 2
Transmission line	DB9F/DB9M multicore cable 9x0,34 shielded or 9-pair twisted cable, UTP 9x2x0,5 (24AWG) shield inside large interferences STP 9x2x0,5 (24AWG).	1-pair or 2-pair twisted cable, UTP Nx2x0,5 (24AWG), shield inside large interferences STP Nx2x0,5 (24AWG)
Standards	EIA-232, CCITT V.24,	EIA-485, CCITT V.11
Max. baud rate	230,4 kbps	
Transmission type	Asynchronism full duplex, half duplex.	
Optical Signalization	<ul style="list-style-type: none"> <li>• RX - red LED data reception on RS-485/RS-422 port,</li> <li>• TX - yellow LED data transmission on RS-485/RS-422 port,.</li> <li>• PWD – green LED (power supply)</li> </ul>	
Electrical Parameters		
Power requirements	10 - 24 – 30 V DC	
Power Cable	Recommended length of power cable – up to 3m	
Power	<1W	
Protection from reverse power polarization	YES	
Galvanic Isolation	1kV= or 3kV= between RS232 interface and power supply. GND of power circuit is the GND of RS485/422 interface.	
Optoisolation	3kV= in signal channel between RS232 and RS485/RS422 interface	
Electromagnetic compatibility	Resistance to disruptions according to the standard PN-EN 55024. Emission of disruptions according to the standard PN-EN 55022.	
Safety requiring	According to the PN-EN60950 norm.	
Environment	Commercial and light industrial.	
Environmental Parameters		
Operating temperature	-30 ÷ 60°C	
Humidity	5 ÷ 95% - non-condensing	
Storage temperature	-40 ÷ 70°C	
Casing		
Dimensions (W x D x H)	84 mm x 59 mm x 23 mm.	
Material	ABS	
Degree of casing protection	IP20	
Weight	0,10 kg	
Implementation of Standard	-----	
Location during work	Free	
Mounting method	-----	

**Dear Customer,**

Thank you for purchasing **CEL-MAR Company** product.

We hope that this user manual helped connect and start up the **ADA-I1040 converter**. We also wish to inform you that we are a manufacturer of the widest selections of data communications products in the world such as: data transmission converters with interface RS232, RS485, RS422, USB, Ethernet, Wi-Fi, Current Loop, Fibre-Optic Converters and other.

Please contact us to tell how you like our products and how we can satisfy you present and future expectation.

**CEL-MAR sp.j.**

Computers Science and Electronic Factory  
str Sciegiennego 219C  
25-116 Kielce, POLSKA

Tel.....: +48 41 362-12-46  
Tel/fax.....: +48 41 361-07-70  
Web.....: <http://www.cel-mar.pl>  
Office.....: [office@cel-mar.pl](mailto:office@cel-mar.pl)  
Sales department.....: [sales@cel-mar.pl](mailto:sales@cel-mar.pl)  
Technical information .....: [support@cel-mar.pl](mailto:support@cel-mar.pl)