

# User manual

## ADA-4040PC9

### Kyma\* KDU-110-SPS to MODBUS-RTU protocol converter



## Contents

1. GENERAL INFORMATION.....	3
1.1. WARRANTED INFORMATION.....	3
1.2. GENERAL CONDITIONS FOR SAFE USE.....	3
1.3. CE LABEL.....	3
1.4. ENVIRONMENTAL PRESERVATION.....	3
1.5. SERVICE AND MAINTENANCE.....	3
1.6. PACK CONTENTS.....	3
2. PRODUCT INFORMATION.....	3
2.1. PROPERTIES.....	3
2.2. DESCRIPTION.....	4
2.3. ISOLATION.....	4
3. INSTALLATION.....	5
3.1. ASSEMBLING.....	5
3.2. CONNECTION TO COMPUTER.....	5
3.3. CONNECTION TO KDU-110 DEVICE.....	5
3.4. CONNECTION TO RS485 BUS.....	5
3.4.1. CONNECTION OF KDU-110 DEVICE TO RS485(4W) MODBUS-RTU BUS.....	6
3.4.2. CONNECTION OF KDU-110 DEVICE TO RS485(2W) MODBUS-RTU BUS.....	6
3.4.3. GND TERMINAL CONNECTION.....	7
3.4.4. LINE TERMINATION Rt.....	7
3.5. POWER SUPPLY CONNECTION.....	7
4. ACTIVATION.....	7
4.1. DESCRIPTION OF SIGNALLING LEDES.....	7
4.2. TROUBLESHOOTING.....	7
5. CONFIGURATION.....	8
5.1. OPERATION MODE.....	8
5.2. CONFIGURATION BY USING ADACONFIG.....	8
5.3. FACTORY DEFAULT.....	9
5.4. FIRMWARE UPDATE.....	10
5.5. EMERGENCY FIRMWARE UPDATE.....	10
6. DATA TRANSMISSION DIAGNOSTICS.....	10
7. OPERATION.....	11
8. IMPLEMENTATION OF MODBUS-RTU PROTOCOL.....	11
8.1. TABLE OF MODBUS-RTU ADDRESSES.....	11
8.1.1. REGISTERS OF CURRENT PARAMETER VALUES KDU-110 DEVICE - READOUT BY FUNCTION 04 (3X – REFERENCES) INPUT REGISTERS.....	11
8.1.2. REGISTERS OF CURRENT PARAMETER VALUES KDU-110 DEVICE - READOUT BY FUNCTION 03 (4X – REFERENCES) HOLDING REGISTERS.....	12
8.2. FRAME STRUCTURE OF MODBUS-RTU PROTOCOL.....	13
8.3. USED FUNCTIONS OF MODBUS-RTU PROTOCOL.....	13
8.3.1. FUNCTION 0x03 / 0x04 - READOUT PARAMETERS VALUES FROM KDU-110.....	13
8.3.1.1. READOUT OF CURRENT PARAMETER VALUE STORED IN 16-BIT REGISTER [4X / 3X-REFERENCES].....	13
9. VERSIONS.....	15
10. SPECIFICATION.....	15

## 1. GENERAL INFORMATION

Thank you for your purchase of **CEL-MAR Company** product. This product has been completely tested and is covered by a two year warranty on parts and operation from date of sale.

If any questions or problems arise during installation or use of this product, please do not hesitate to contact Technical Support at +48 41 362-12-46 or e-mail [support@cel-mar.pl](mailto:support@cel-mar.pl).

### 1.1. WARRANTED INFORMATION

**ADA-4040PC9** converter is covered by a two year warranty from date of sale. In case of being damaged it will be repair or the damaged component will be replace. The warranty does not cover damage caused from improper use, materials consumption or any unauthorized changes. If the product does not function (is damaged), or not operate in accordance with the instructions, will be repaired or replaced.

All warranty and no warranty repairs must be returned with paid transport and insuring to the **CEL-MAR Company**.

**CEL-MAR Company** under no circumstances won't be responsible for ensuing damage from improper using the product or as a result of random causes: the lightning discharge, the flood, the fire and the like.

**CEL-MAR Company** is not be held responsible for damages and loss including: loss of profits, loss of data, pecuniary losses ensuing from using or the impossibility of using this product.

In specific cases **CEL-MAR Company** discontinue all warranties and in particular do not follow the user manual and do not accept terms of warranty by the user.

### 1.2. GENERAL CONDITIONS FOR SAFE USE

The device should be installed in a safe and stable places (eg, electroinstallation cabinet), the powering cable should be arranged so as not to be exposed to trampling, attaching, or pulling out of the circuit.

Do not put device on the wet surface.

Do not connect devices for nondescript powering sources,

Do not damage or crush powering wires.

Do not make connection with wet hands.

Do not adapt, open or make holes in casings of the device!

Do not immerse device in water or no other liquid.

Do not put the fire opened on device sources: candles, an oil lamps and the like.

Complete disable from the supply network is only after disconnecting the power supply circuit voltage.

Do not carry out the assembly or disassembly of the device if it is enabled. This may result to short circuit and damage the device.

The device can not be used for applications that determine human life and health (eg. Medical).

### 1.3. CE LABEL



The CE symbol on the device CEL-MAR means compatibility with electromagnetic compatibility Electromagnetic Compatibility Directive **EMC 2014/30/WE**.

Declaration of Conformity is delivered with purchased device.

### 1.4. ENVIRONMENTAL PRESERVATION



This sign on the device inform about putting expended device with other waste materials. Device should send to the recycling. (In accordance with the act about the Electronic Appliance Expended from day 29 of July 2005)

### 1.5. SERVICE AND MAINTENANCE

Converter ADA-4040PC9 does not require the servicing and maintenance.

Technical support is available at number +48 41 362-12-46 in 8.00-16.00, from Monday to Friday or e-mail [support@cel-mar.pl](mailto:support@cel-mar.pl).

### 1.6. PACK CONTENTS

ADA-4040PC9 converter; User Manual; CE declaration; Line terminators 120Ω (2 szt.).

## 2. PRODUCT INFORMATION

### 2.1. PROPERTIES

- Conversion of protocols KDU-110-SPS (RS485) to MODBUS-RTU (RS485/RS422),
- Parameters, baud rate and data format conversion on RS485/RS422 and RS485 converter's ports,
- Operating on 2 or 4 wire buses in RS485/RS422 standard in point-to-point and multipoint mode,
- Conversion TX, RX signals of RS485 standard to RS485/RS422 standard and inversely,
- Operation up to 32 devices on RS485 bus,
- Baud rate set on RS485 (KDU) & RS485/RS422 (RTU) (bps): 300, 600, 1200, 1800, 2400, 4800, 7200, 9600, 14400, 19200, 28800, 38400, 57600, 76800, 115200, 230400,
- Data format set on RS232 & RS485/RS422 interfaces: data bit: 5, 6, 7, 8; parity: None, Odd, Even; number of stop bits: 1, 2,
- Power supply 10 - 30 VDC stable min. 2W,
- ~3kV= optoisolation in signal channel between RS485 and RS485/422 interfaces,
- 1kV= or 3kV= galvanic isolation between RS485 & RS485/422 interfaces and power supply (depends on version),
- Implemented short circuit protection and over-voltage protection on RS485 / RS422 network,
- Implemented ESD 15kV surge protector of RS485 interface,
- Connection MODBUS-RTU RS485 / RS422 network and power supply via screw terminal block 2.5 mm<sup>2</sup>.
- Connection KDU-110 via screw terminal block 2.5 mm<sup>2</sup>
- Cover compatible with DIN 43880 standard– mounting in typical electro-installation unit,
- Cover adapt to rail mounting according to DIN35 / TS35 standard,
- Cover dimensions (W x D x H) 53mm x 63mm x 90mm,

## 2.2. DESCRIPTION

Protocol converter KDU-110-SPS to MODBUS-RTU ADA-4040PC9 is a device, which allow connecting Kyma\* KDU-110 Shaft Power Meter (SPS) devices, equipped with RS485 interface to multipoint RS-485 bus, to which are connected devices communicate by MODBUS- RTU protocol. Simultaneously, the converter convert RS485 to RS485/422 standards, with setting of data format. Depending on configurations, can be set baud rate, data bits, parity, number of stop bits. The setting can be different for (KDU)RS485 i (RTU)RS485/RS422 ports.

The converter support the asynchronous transmission data with baud rate 230,4 kbps. through one or two pairs of twisted-pair cables of RS485/RS422 interface.

ADA-4040PC9 has screw terminal blocks for connection of RS485 interface KDU-110-SPS device, MODBUS RS485/422 bus and power supply. ADA-4040PC9 use Tx, Rx for communication with RS485 interface.

Overvoltage protection was made on base safety diodes and fuses on each RS485/RS422 lines.

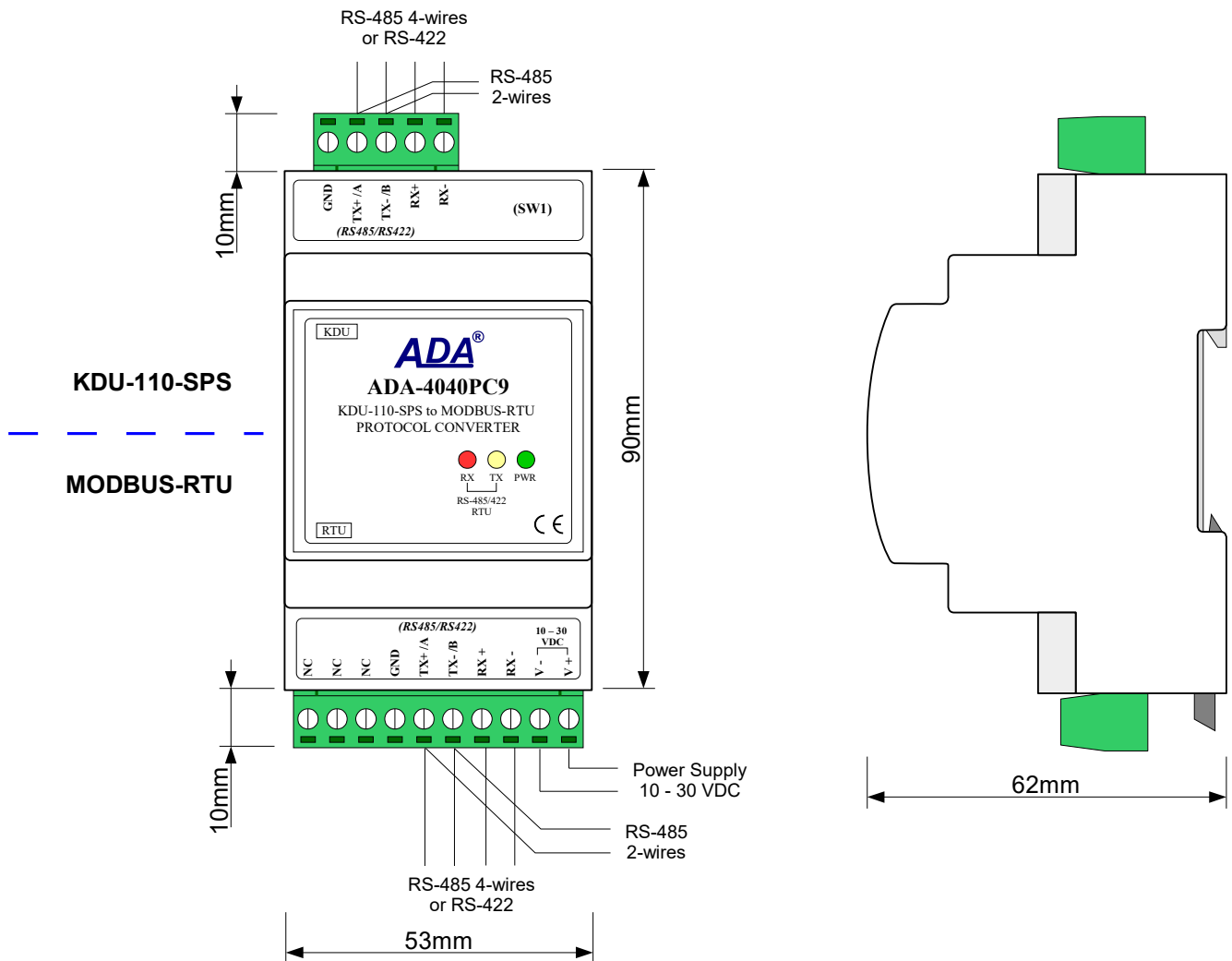

Fig. 1. ADA-4040PC9 view and location of SW1

## 2.3. ISOLATION

Converter ADA-4040PC9 has 3-way galvanic isolation on the levels 1kV= or 3kV=, depending on version described in section VERSIONS.

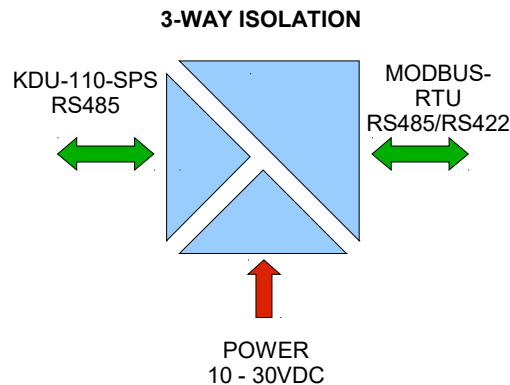

Fig. 2. Isolation structure

### 3. INSTALLATION

This chapter will show how to use and connect ADA-4040PC9 to KDU-110 device, RS485/RS422 network and power supply. In the purpose of minimization of disruptions from environment is being recommended to:

- apply multipair type shielded cables, which shield can be connected to the earthing on one end of the cable,
- arrange signal cables in the distance not shorter than 25 cm from powering cables.
- apply cable of adequate cross-section due to voltage drops for converter powering,
- use suppression filters for powering converters that are installed within a single object.
- not supply converter from power circuit device that generates large impulse interference such as transmitters, contactors, falowniki.

#### 3.1. ASSEMBLING

The cover of ADA-4040PC9 converter is adapted to assembly on TS-35 (DIN35) rail. To install the converter, should be mounted on the rail upper part of the cover, then press bottom part to hear characteristic „Click” sound.

#### 3.2. CONNECTION TO COMPUTER

To connect ADA-4040PC9 to computer is needed additional converter e.g. ADA-I9141 USB to RS485/RS422 converter; connected to KDU-110-SPS (5-pin connector) port of the converter.

Typical connections of ADA- 4040PC9 to PC are shown below.

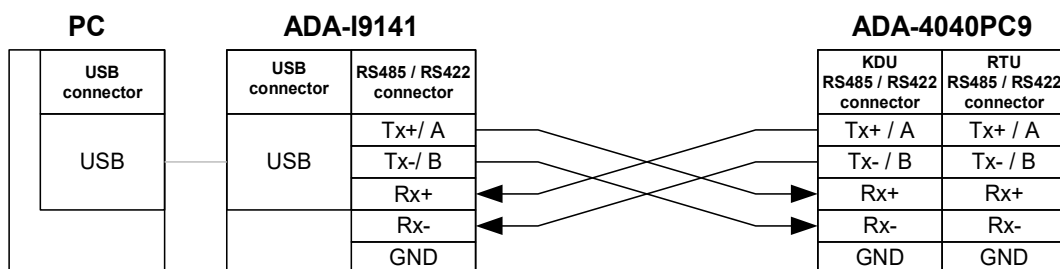

Fig 3. 4-Wires connection of ADA-4040PC9 to PC by the use of ADA-I9141 – USB to RS485/RS422 converter.

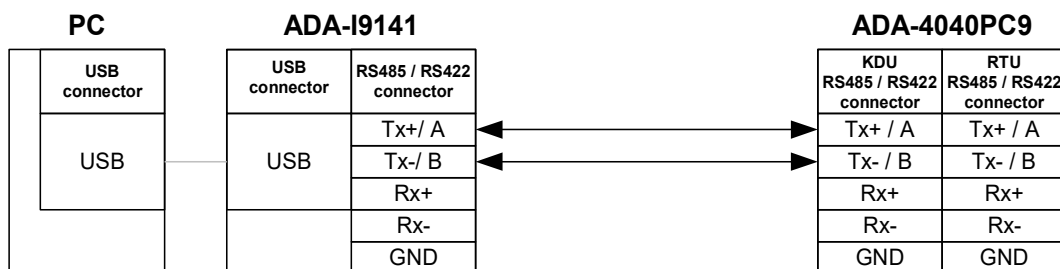

Fig 4. 2-Wires connection of ADA-4040PC9 to PC by the use of ADA-I9141 – USB to RS485/RS422 converter.

#### 3.3. CONNECTION TO KDU-110 DEVICE

In case of connection ADA-4040PC9 converter to communication port of KDU-110 device, should be made a cable according to below diagram.

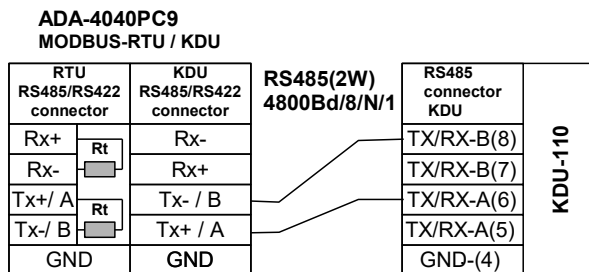

Fig 5. Connection of ADA-4040PC9 to communication port of KDU-110 device.

#### 3.4. CONNECTION TO RS485 BUS

RS485/RS422 interface in ADA-4040PC9 converter is available on screw terminal block and is described as: Tx+/A, Tx-/B, Rx+, Rx-, GND.

Connection of ADA-4040PC9 to RS485(4W) and RS485(2W) network are shown below.

**3.4.1. CONNECTION OF KDU-110 DEVICE TO RS485(4W) MODBUS-RTU BUS**

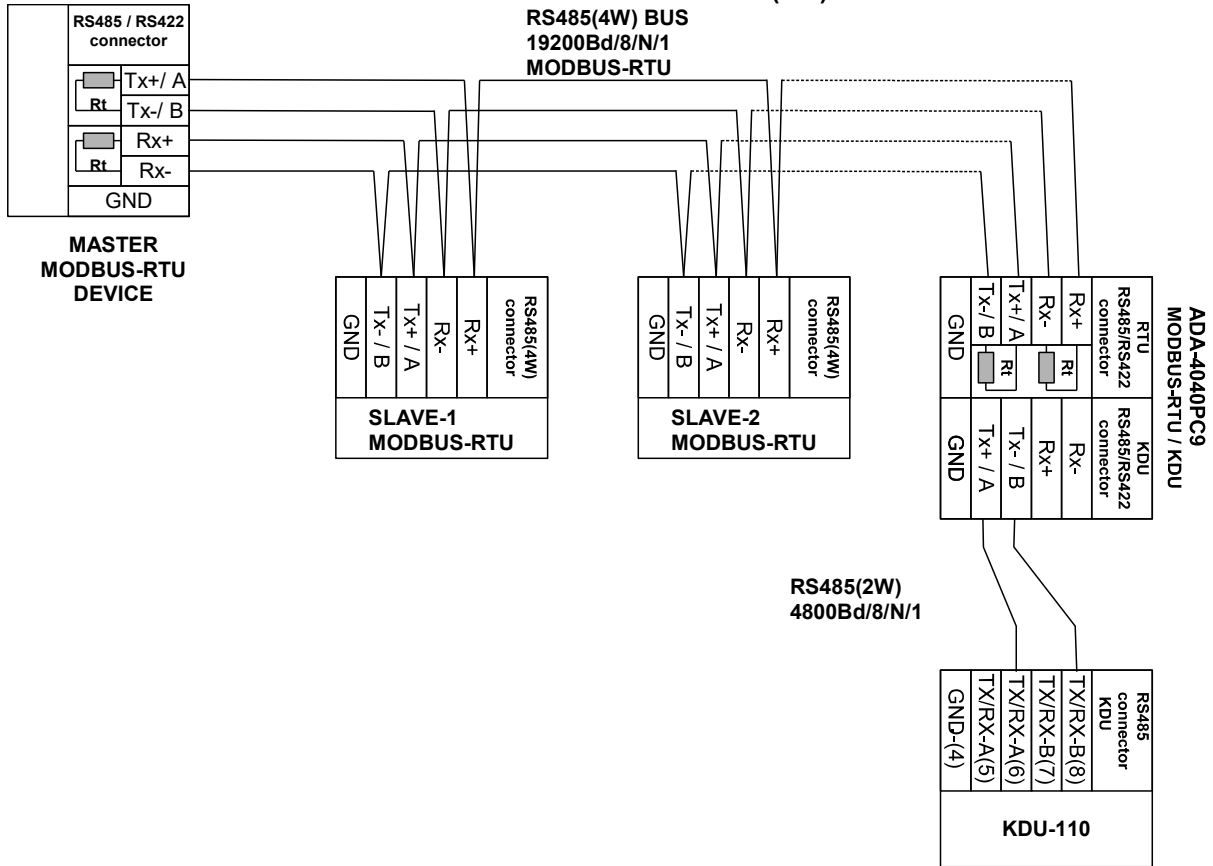

Fig. 6. Example connection of KDU-110 device by the use of ADA-4040PC9 to RS485(4W) 4-wire bus.

**3.4.2. CONNECTION OF KDU-110 DEVICE TO RS485(2W) MODBUS-RTU BUS**

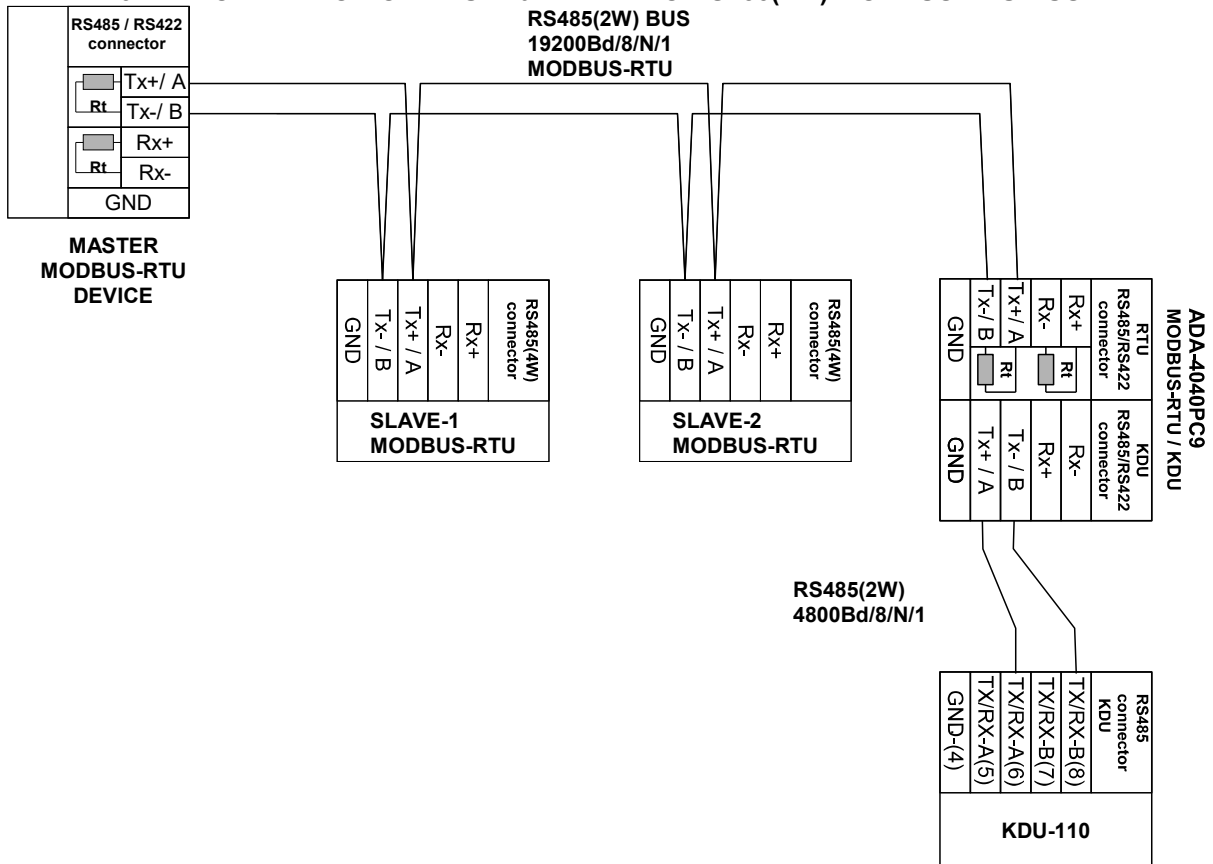

Fig. 7. Example connection of KDU-110 device by the use of ADA-1040PC9 to RS485(2W) 2-wire bus.

### 3.4.3. GND TERMINAL CONNECTION

Connection of GND terminals of RS485/422 interfaces, devices connected to RS485/422 bus, should be done in the case of a potential difference of the signals grounds on interfaces RS485 / RS422, which prevents proper data transmission.

**Cannot connect to the GND terminal - cables screens, PE circuit of electrical installation, signals grounds of other devices.**

### 3.4.4. LINE TERMINATION Rt

The application of Line Termination (terminator)  $R_t = 120$  ohms will reduce electrical reflection in data line at high baud rate. It is not needed below 9600Bd. Should be used the Line Termination resistor if the distance is over 1000m @ 9600Bd or 700m @ 19200Bd, and if the disturbance in transmission will appear.

Example connection of  $R_t$  are shown on Fig. 5 & 6. Two  $R_t = 120 \Omega$ , 5%, 0,25W are delivered with the converter.

### 3.5. POWER SUPPLY CONNECTION

To connect power supply to the converter, should have DC power supplies (regulated) output voltage from 10 V= to 30V=, min. nominal power 2W, e.g. HDR-15-24. Power cable from DC power supplies to device can not be longer than 3m.

Should connect positive (+) end of DC power supplies to V+ device terminal and negative (-) end to V- on terminal block.

ADA-4040PC9 has protection against power supply reverse connection.

## 4. ACTIVATION

The converter can be power on after properly connection according to section above.

If after connection power supply on front panel will not light green led PWR, check correctness of power supply connecting (polarization). When data is present the LEDs Tx and Rx should blink.

### ATTENTION!!

**AT BAUD RATE ABOVE 38.4 Kbps THE LED'S TX, RX WILL LIGHT WEAKLY DURING DATA TRANSMISSION**

### 4.1. DESCRIPTION OF SIGNALLING LEDS

LED	Description
PWR	Signalling of Power Supply
RX	Signalling of data receiving through ADA-4040PC9 from RS485/RS422 port – MODBUS-RTU
TX	Signalling of data transmitting from ADA-4040PC9 through RS485/RS422 port – MODBUS-RTU
Yellow LED by SW1	Not light – signalling of normal operating mode (RUN)
	Blinking at frequency 1 Hz - signalling of configuration mode or software data flowing to the converter
	Blinking at frequency 2 Hz - signalling of factory default mode
	Lit continuously – signalling of emergency firmware update

### 4.2. TROUBLESHOOTING

Problem	Solutions
PWR LED is not light	Check polarization and parameters of connected power supply.
Rx LED lights continuously	RS485(4W) /422 network. Wrong polarization on terminals: Rx+, Rx-; change polarization.
No transmission Tx LED is blinking	RS485(4W) / RS422 network. Check correctness of connection to terminals Tx, Rx; according to point 3 and the converter configuration.

## 5. CONFIGURATION

### 5.1. OPERATION MODE

ADA-4040PC9 converter can operate in a few modes :

- run,
- configuration,
- factory default,
- emergency firmware update

Those modes can be set by use SW1 located by screw terminal block KDU port. To set the switch section, should remove the cover marked as SW1 and make the appropriate settings by the use a small, flat screwdriver.

All available adjusting the SW1 switch are shown in table below.

#### Converter operation modes

SW1- 1	SW1- 2	Mode
OFF	OFF	Run
ON	OFF	Configuration
OFF	ON	Factory default
ON	ON	Emergency Firmware Update

### 5.2. CONFIGURATION BY USING ADACONFIG

The configuration of ADA-4040PC9 converter can be made by the use of *ADAConfig* Software, which should be download from web side of ADA-4040PC9 converter ([www.cel-mar.pl/en/rs485rs422\\_rs485rs422\\_kdu110\\_rtu\\_4040pc9.htm](http://www.cel-mar.pl/en/rs485rs422_rs485rs422_kdu110_rtu_4040pc9.htm)), tab **Download**, and then extract *adaconfig.zip* file and run **setup.exe**.

After installation ADAConfig software is available in menu **Win10 Start > CEL-MAR > ADAConfig** and icon ADAConfig on Desktop.

To make the configuration, connect converter to computer and power supply. If after power, on the front panel is not lit green LED PWR, check the power connection (polarity). If the PWR LED lights, set the section of SW1 switch to configuration mode as in table below.

SW1-1	SW1-2
ON	OFF

In the configuration mode the yellow LED located by SW1 micro-switch will blink with frequency 1 Hz. Start the ADAConfig Software and make the configuration of transmission parameters for each converter interfaces. First should be set the number of **[COM port]** **[1]** for communication with the converter, then readout the configuration from ADA-4040PC9 memory, using the button **[Read configuration]** **[2]** and make the proper changes of each interfaces setting, as below.

**[3]** setting converter address from side RS485 MODBUS-RTU bus,

In the section **[Converter Address]** select the field **[Enable]** and in the field **[Address]** enter the address of SLAVE MODBUS-RTU converter, from the scope 1-247.

**[4]** setting of transmission parameters for the **KDU110** (RS485) port:

- baud rate (kbps) : 0.3, 0.6, 1.2, 1.8, 2.4, 4.8, 7.2, 9.6, 14.4, 19.2, 28.8, 38.4, 57.6, 76.8, 115.2, 230.4,
- number of data bites: 5, 6, 7, 8,
- control parity: no control, parity control, control of none parity,
- number of stop bits : 1, 2,
- frame spacing – range from 1 to 255 (time silence as frame's end),

**[5]** setting transmission parameters for the **RTU** (MODBUS-RTU) port:

- baud rate (kbps) : 0.3, 0.6, 1.2, 1.8, 2.4, 4.8, 7.2, 9.6, 14.4, 19.2, 28.8, 38.4, 57.6, 76.8, 115.2, 230.4,
- number of data bites: 5, 6, 7, 8,
- control parity: no control, parity control, control of none parity,
- number of stop bits : 1, 2,
- frame spacing – range from 1 to 255 (time silence as frame's end),

After configuration, the setting should be saved on converter memory by using button **[Write configuration]** **[6]**. Return to work in run mode is made by using SW1 switch as below.

SW1-1	SW1-2
OFF	OFF

The yellow LED (located near the SW1) will turn off in the RUN mode.



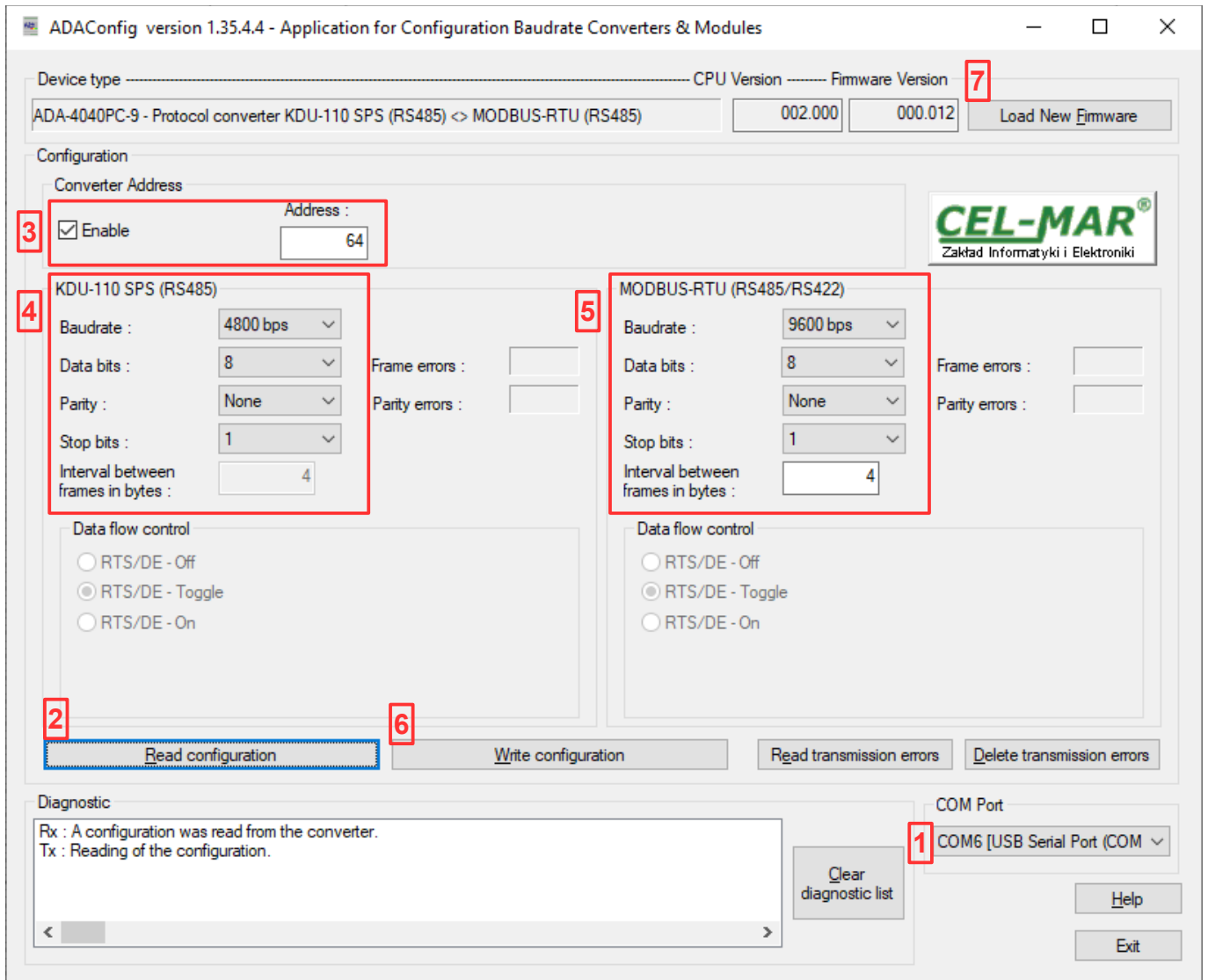

Fig. 8. View of ADAConfig software interface

**5.3. FACTORY DEFAULT**

In case of faulty functioning ADA-4040PC9, can be restored the factory default setting of the converter internal registers. Set SW1 microswitch mode as in the table below.

<b>SW1-1</b>	<b>SW1-2</b>
OFF	ON

**Disconnect** the power and after while **connect** again the power. After that, will be loaded the factory default setting to the converter internal registers.

After this operation, the converter parameters should be set again for operating in the application.

Set micro switch SW1 to run mode as shown in the table below.

<b>SW1-1</b>	<b>SW1-2</b>
OFF	OFF

The yellow LED (located near the SW1) will turn off in the RUN mode.

**Factory Default**

<b>Parameter</b>	<b>KDU RS485 Interface</b>	<b>RTU RS485/RS422 Interface</b>
Baud rate	4800bps	9600bps
Number of data bites	8	8
Control parity	No	No
Stop bits	1	1
Frame spacing	4	4

## 5.4. FIRMWARE UPDATE

Set SW1 micro switch to configuration mode as in table below.

SW1-1	SW1-2
ON	OFF

In the configuration mode the yellow LED will blink with frequency 1Hz. Press a button **[Load New Firmware] [7]** to change the software delivered by manufacturer. The Select File window will open (fig. below) and select the \*.bin file then click **[Open]** – software will be load to ADAConfig buffer storage and will be checked. If the ADAConfig not detect errors in loaded file, change converter software. Process of updating is visualized by ADAConfig in use Progress Window and after proper changing confirmed by correct message.

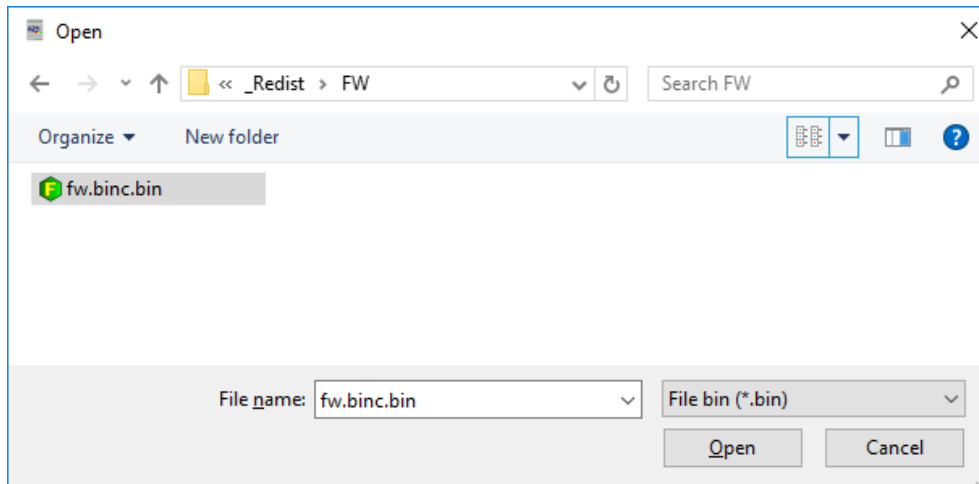

Fig.9. Selection of firmware file

During loading software the yellow LED located beside SW1 micro-switch will blink, showing data flow to the converter. If the software was loaded correctly yellow LED will be blink with frequency 1 Hz.

After that, set microswitch SW1 to run mode as shown in the table below.

SW1-1	SW1-2
OFF	OFF

The yellow LED (located near the SW1) will turn off in the RUN mode.

## 5.5. EMERGENCY FIRMWARE UPDATE

In case of the unsuccessful update of the converter software, try again according to description in the above point. If the update is still incorrect use emergency firmware update. Set SW1 microswitch mode as in the table below.

SW1-1	SW1-2
ON	ON

After microswitch setting, should be restarted ADA-4040PC9, by turning OFF and then ON the power supply. The yellow LED will light continuously and the converter will be in Emergency Firmware Update mode. Now follow the description in the above point.

After successful software update, set microswitch SW1 to the run mode as shown in the table below.

SW1-1	SW1-2
OFF	OFF

The yellow LED (located near the SW1) will turn off in the RUN mode.

## 6. DATA TRANSMISSION DIAGNOSTICS

To readout diagnostics, the SW1 microswitch should be set to the configuration mode.

SW1-1	SW1-2
ON	OFF

In the configuration mode the yellow LED will blink with frequency 1Hz..

Correctness of transmission proceed on KDU-110(RS485) and RTU (RS485) interfaces, can be checked by readout the errors list by ADAConfig Software from the converter memory.

Frames error counter will be increased, in case of: improper speed set compared to real speed of data transmission.

Parity error counter will be count the errors which can arise in case of misrepresent bytes in transmitted sign. This counter will not work in case of disable control parity.

To check those counters press the button **[Read transmission errors]**, and to delete (zeroing of counters in the memory of the converter) press **[Delete transmission errors]**. In case of parity errors or frame errors, should be checked the ADA-4040PC9 converter's configuration and correctness connection of RS485 bus to RTU and KDU-110 converter ports.

After finishing the diagnostics, the SW1 microswitch should be set to the run mode as shown in the table below.

SW1-1	SW1-2
OFF	OFF

The yellow LED (located near the SW1) will turn off in the RUN mode.

## 7. OPERATION

ADA-4040PC9 is protocol converter of KDU-110-SPS to MODBUS-RTU protocols, **with possibility of conversion a baud rate, a data format (number of data bits, parity bit, stop bits)**. Additionally, is a separator of RS485 (KDU-110-SPS) port from RS485/RS422 (MODBUS-RTU) port.

If KDU-110 device will be connected to the RS485 (KDU) port, to RS485/RS422 (RTU) port should be connected RS485/RS422 MODBUS-RTU bus.

Frames of MODBUS protocol having the errors CRC are rejected by the converter.

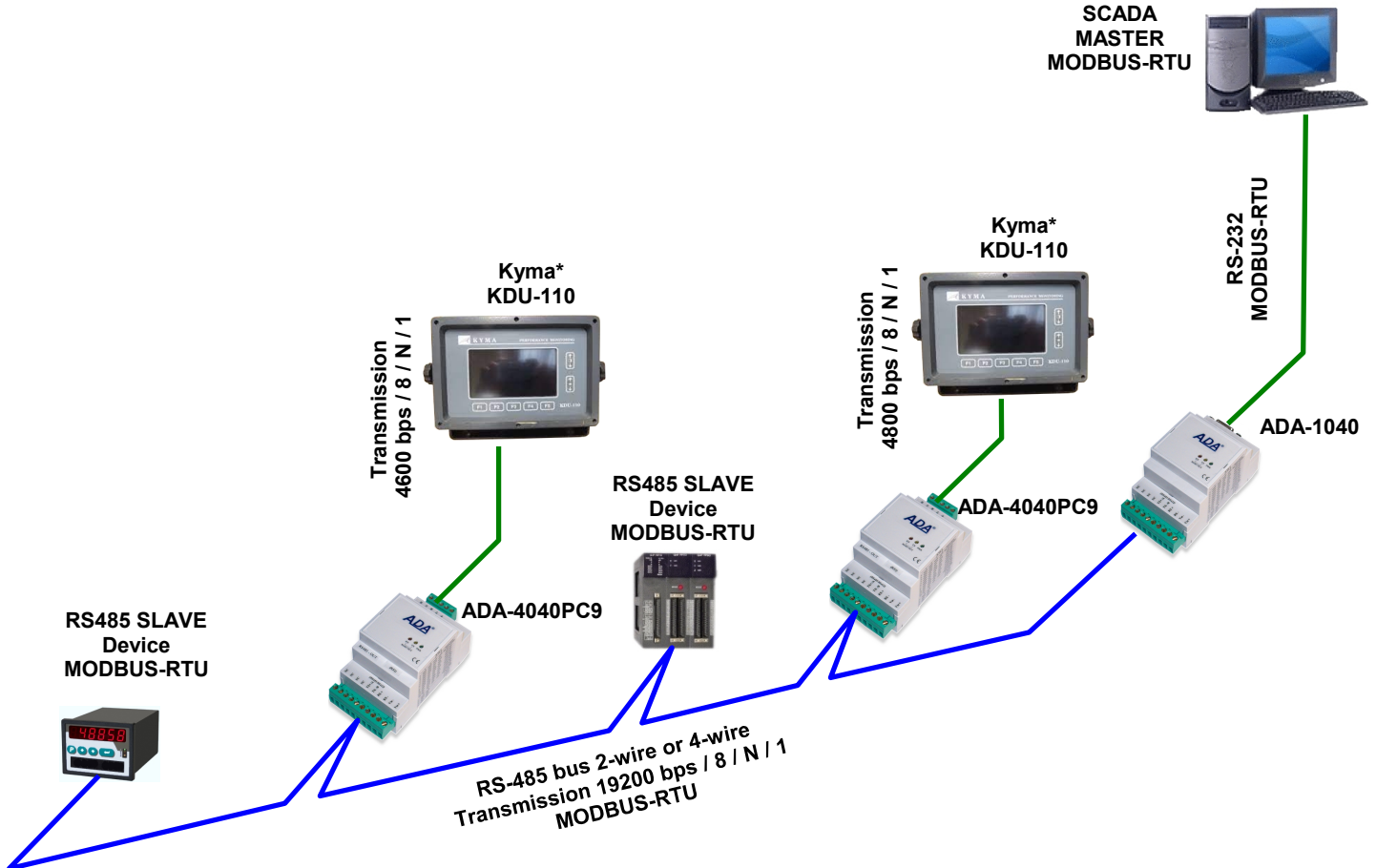

Fig. 10. Connection of KDU-110 to RS485 MODBUS-RTU bus.

## 8. IMPLEMENTATION OF MODBUS-RTU PROTOCOL

ADA-4040PC9 protocol converter allows connecting KDU-110 device as SLAVE to RS485 MODBUS-RTU bus. The length of RS485 bus can be extended (another 1200m) by the use of ADA-4040 repeaters or ADA-4044H HUBS RS485.

The MODBUS-RTU protocol used for communication between ADA-4040PC9 converters and SCADA system or PLC controller enable easy integration of KDU-110 device in existing automation systems.

### 8.1. TABLE OF MODBUS-RTU ADDRESSES

#### 8.1.1. REGISTERS OF CURRENT PARAMETER VALUES KDU-110 DEVICE - READOUT BY FUNCTION 04 (3X – REFERENCES) INPUT REGISTERS

Address 3X	Registers Address	Register description	Attribute	Value
30001	0	TALKER ID = SA BYTE HI = 0x54 = 84 (ASCII – S ) BYTE LO = 0x41 = 65 (ASCII – A )	R	16-bit register U16
30002	1	PARAMETER#1 – Module number BYTE HI = 0x00 BYTE LO = 0x01 – Module number	R	16-bit register U16
30003	2	PARAMETER#2 – Code : A (0x41) – normal, B(0x42) - overtorque BYTE HI = 0x00 BYTE LO = 0x41 – A	R	16-bit register U16

Address 3X	Registers Address	Register description	Attribute	Value
30004	3	<b>TORQUE [Tm]</b> TORQUE DWORD = 1074 = 0x00 00 04 32 WORD LO = 0x04 32; BYTE HI = 0x04; BYTE LO = 0x32	R	16-bit register U32 LO DW=10
30005	4	TORQUE DWORD = 1074 = 0x00 00 04 32 WORD HI = 0x00 00; BYTE HI = 0x00; BYTE LO = 0x00	R	16-bit register U32 HI DW=10
30006	5	<b>THRUST [T]</b> THRUST DWORD = 1108 = 0x00 00 04 54 WORD LO = 0x204 54; BYTE HI = 0x04; BYTE LO = 0x54	R	16-bit register U32 LO DW=10
30007	6	THRUST DWORD = 1108 = 0x00 00 04 54 WORD HI = 0x00 00; BYTE HI = 0x00; BYTE LO = 0x00	R	16-bit register U32 HI DW=10
30008	7	<b>RPM [rpm]</b> RPM DWORD = 1045 = 0x00 00 04 15 WORD LO = 0x04 15; BYTE HI = 0x04; BYTE LO = 0x15	R	16-bit register U32 LO DW=1
30009	8	RPM DWORD = 1045 = 0x00 00 04 15 WORD HI = 0x00 00; BYTE HI = 0x00; BYTE LO = 0x00	R	16-bit register U32 HI DW=1
30010	9	<b>POWER [SHp]</b> POWER DWORD = 21450 = 0x00 00 53 CA WORD LO = 0x53 CA; BYTE HI = 0x53; BYTE LO = 0xCA	R	16-bit register U32 LO DW=1
30011	10	POWER DWORD = 21450 = 0x00 00 53 CA WORD HI = 0x00 00; BYTE HI = 0x00; BYTE LO = 0x00	R	16-bit register U32 HI DW=1
30012	11	<b>ENERGY [SHph]</b> ENERGY DWORD = 3456789 = 0x00 34 BF 15 WORD LO = 0xBF 15; BYTE HI = 0xBF; BYTE LO = 0x15	R	16-bit register U32 LO DW=1
30013	12	ENERGY DWORD = 3456789 = 0x00 34 BF 15 WORD HI = 0x00 34; BYTE HI = 0x00; BYTE LO = 0x34	R	16-bit register U32 HI DW=1
30014	13	<b>TOTAL REVOLUTIONS</b> TOTAL REVOLUTIONS DWORD = 343434 = 0x00 05 3D 8A WORD LO = 0x3D 8A; BYTE HI = 0x3D; BYTE LO = 0x8A	R	16-bit register U32 LO DW=1
30015	14	TOTAL REVOLUTIONS DWORD = 343434 = 0x00 05 3D 8A WORD HI = 0x00 05; BYTE HI = 0x00; BYTE LO = 0x05	R	16-bit register U32 HI DW=1

**8.1.2. REGISTERS OF CURRENT PARAMETER VALUES KDU-110 DEVICE - READOUT BY FUNCTION 03 (4X – REFERENCES) HOLDING REGISTERS**

Address 4X	Registers Address	Register description	Attribute	Value
40001	0	<b>TALKER ID = SA</b> BYTE HI = 0x54 = 84 (ASCII – S ) BYTE LO = 0x41 = 65 (ASCII – A )	R	16-bit register U16
40002	1	<b>PARAMETER#1 – Module number</b> BYTE HI = 0x00 BYTE LO = 0x01 – Module number	R	16-bit register U16
40003	2	<b>PARAMETER#2 – Code : A (0x41) – normal, B(0x42) - overtorque</b> BYTE HI = 0x00 BYTE LO = 0x41 – A	R	16-bit register U16
40004	3	<b>TORQUE [Tm]</b> TORQUE DWORD = 1074 = 0x00 00 04 32 WORD LO = 0x04 32; BYTE HI = 0x04; BYTE LO = 0x32	R	16-bit register U32 LO DW=10

Address 4X	Registers Address	Register description	Attribute	Value
40005	4	TORQUE DWORD = 1074 = 0x00 00 04 32 WORD HI = 0x00 00; BYTE HI = 0x00; BYTE LO = 0x00	R	16-bit register U32 HI DW=10
40006	5	<b>THRUST [T]</b> THRUST DWORD = 1108 = 0x00 00 04 54 WORD LO = 0x204 54; BYTE HI = 0x04; BYTE LO = 0x54	R	16-bit register U32 LO DW=10
40007	6	THRUST DWORD = 1108 = 0x00 00 04 54 WORD HI = 0x00 00; BYTE HI = 0x00; BYTE LO = 0x00	R	16-bit register U32 HI DW=10
40008	7	<b>RPM [rpm]</b> RPM DWORD = 1045 = 0x00 00 04 15 WORD LO = 0x04 15; BYTE HI = 0x04; BYTE LO = 0x15	R	16-bit register U32 LO DW=1
40009	8	RPM DWORD = 1045 = 0x00 00 04 15 WORD HI = 0x00 00; BYTE HI = 0x00; BYTE LO = 0x00	R	16-bit register U32 HI DW=1
40010	9	<b>POWER [SHp]</b> POWER DWORD = 21450 = 0x00 00 53 CA WORD LO = 0x53 CA; BYTE HI = 0x53; BYTE LO = 0xCA	R	16-bit register U32 LO DW=1
40011	10	POWER DWORD = 21450 = 0x00 00 53 CA WORD HI = 0x00 00; BYTE HI = 0x00; BYTE LO = 0x00	R	16-bit register U32 HI DW=1
40012	11	<b>ENERGY [SHph]</b> ENERGY DWORD = 3456789 = 0x00 34 BF 15 WORD LO = 0xBF 15; BYTE HI = 0xBF; BYTE LO = 0x15	R	16-bit register U32 LO DW=1
40013	12	ENERGY DWORD = 3456789 = 0x00 34 BF 15 WORD HI = 0x00 34; BYTE HI = 0x00; BYTE LO = 0x34	R	16-bit register U32 HI DW=1
40014	13	<b>TOTAL REVOLUTIONS</b> TOTAL REVOLUTIONS DWORD = 343434 = 0x00 05 3D 8A WORD LO = 0x3D 8A; BYTE HI = 0x3D; BYTE LO = 0x8A	R	16-bit register U32 LO DW=1
40015	14	TOTAL REVOLUTIONS DWORD = 343434 = 0x00 05 3D 8A WORD HI = 0x00 05; BYTE HI = 0x00; BYTE LO = 0x05	R	16-bit register U32 HI DW=1

**8.2. FRAME STRUCTURE OF MODBUS-RTU PROTOCOL**

Device address (1-byte)	Function (1-byte)	Dane (n-bytes)	CRC-16Lo (1-byte)	CRC-16Hi (1-byte)
-------------------------	-------------------	----------------	-------------------	-------------------

**8.3. USED FUNCTIONS OF MODBUS-RTU PROTOCOL**

Function code	Description
03 (0x03)	Readout parameters & value KDU-110 device from converter MODBUS-RTU registers
04 (0x04)	Readout parameters & value KDU-110 device from converter MODBUS-RTU registers

**8.3.1. FUNCTION 0x03 / 0x04 - READOUT PARAMETERS VALUES FROM KDU-110**

**8.3.1.1. READOUT OF CURRENT PARAMETER VALUE STORED IN 16-BIT REGISTER [4X / 3X-REFERENCES]**

Function 0x03 / 0x04 are used for readout of parameters values of KDU-110 from the converter.

The parameter value is read from MODBUS-RTU register and is presented by a 16-bit register.

The registers with parameter value are in the integer format of 16-bit or 32-bit with the sign or without (in C/C++ short type int or unsigned int).

The actual parameter value is obtained from the read register using the following algorithms, using the appropriate factor value **DW** (see table below).

**Algorithm 1.** Readout register is saved to regular type variable (float) and then divide it by the factor **DW**.

```
// Fragment of code in C language (VS6.0) presenting above algorithm
short int siRegParam;
float fValueParam;
.....
fValueParam = (float)siRegParam;
fValueParam = fValueParam / DW;
```

**Algorithm 2.** Readout register is saved to regular type variable 16-bit (short int) and then divide by the factor **DW**, received change of the dividing it is a number of the hundredth parts of the parameter value.

```
// Fragment of code in C language (VS6.0) presenting above algorithm
short int siRegParam;
div_t div_ValueParam;
.....
div_ValueParam = div((int)siRegParam, DW)
printf( "Total parameter value = %d\n, hundredth parts of the parameter value = %d\n",
        div_ValueParam .quot, div_ValueParam .rem );
```

### Query about TORQUE

Byte no	Designation	Size	Value [hex]
00	ADA-4040PC9 address	1 Byte	11 [ 1 to F7]
01	Function code	1 Byte	03 / 04
02	Registry address Hi	1 Byte	00
03	Registry address Lo	1 Byte	03
04	Registry number Hi	1 Byte	00
05	Registry number Lo	1 Byte	02
06	CRC-Lo	1 Byte	---
07	CRC-Hi	1 Byte	---

Example. Query of TORQUE from register address 40003-40004 / address 30003- 30004

**11-03-00-03-00-02-CRCLo-CRCHI**  
**11-04-00-03-00-02-CRCLo-CRCHI**

### Response with TORQUE value

Byte no	Designation	Size	Value [hex]
00	ADA-4040PC9 address	1-Byte	11 [ 1 to F7]
01	Function code	1-Byte	03 / 04
02	Number of data bytes	N-Byte	04
03	Data1-Hi	1-Byte	04
04	Data1-Hi	1-Byte	32
06	Data1-Lo	1-Byte	00
07	Data1-Lo	1-Byte	00
08	CRC-Lo	1-Byte	---
09	CRC-Hi	1-Byte	---

Example. Readout of TORQUE from register address 40003-40004 / address 30003- 30004

**11-03-04-04-32-00-00-CRCLo-CRCHI**  
**11-04-04-04-32-00-00-CRCLo-CRCHI**

In respond TORQUE is presented as 4-byte with values:  
**TORQUE = 1074 = 0x00 00 04 32 => 1074/10 => 107.4**

### Response – in case of exception

Byte no	Designation	Size	Value [hex]
00	ADA-4040PC9 address	1-byte	11 [ 1 to F7]
01	Function code	1-byte	83 / 84
02	Exception code	1-byte	01 – unknown function 02 – unknown data address 03 – unknown data value 04 – KDU-110 device not respond or is faulty
03	CRC-Lo	1-byte	
04	CRC-Hi	1-byte	

### ATTENTION !

TO ADA-4040PC9 CAN BE SENT ALSO MODBUS-RTU QUERY ABOUT ALL OR SELECTED REGISTERS OF KDU-110 DEVICE.

## 9. VERSIONS

Version:	Standard	3-way galvanic isolation:
	1	
Reserved	1	
1kVDC	23	
3kVDC	33	

ADA-4040PC9 - [ ] - [ ]

Order example:  
Product Symbol: **ADA-4040PC9-1-23**  
1 – standard version,  
23 - 1 kV =, 3-way galvanic isolation,

## 10. SPECIFICATION

TECHNICAL DATE		
Transition Parameters		
Protocol	Kyma* KDU-110	Modbus-RTU
Interface	RS-485/RS-422 ( KDU )	RS-485/RS-422 ( RTU )
Connector	Screw terminal, wire max. Ø 2,5mm <sup>2</sup>	Screw terminal, wire max. Ø 2,5mm <sup>2</sup>
Line length	1200 m	1200 m
Max. number of connected device	32	32
Transmission line	Twisted cable 1-pair or 2-pair , UTP Nx2x0,5 (24AWG), shield inside large interferences STP Nx2x0,5(24AWG)	Twisted cable 1-pair or 2-pair , UTP Nx2x0,5 (24AWG), shield inside large interferences STP Nx2x0,5(24AWG)
Standards	EIA-485, CCITT V.11	EIA-485, CCITT V.11
Baud rates (bps)	Up to 230,4 kbps	
Transmission type	Asynchronism full duplex, half duplex.	
Optical signalisation	<ul style="list-style-type: none"> <li>• PWR – green LED power supply,</li> <li>• RX - red LED data receiving from RS485/RS422 (RTU) interface,</li> <li>• TX - yellow LED data transmission through RS485/RS422 (RTU) interface.</li> </ul>	
Electrical Parameters		
Power requirements	10 - 24 – 30 V DC	
Power Cable	Recommended length of power cable - up it is 3m.	
Power	<2W	
Protection from reverse power polarization	YES	
Galvanic Isolation	1kVDC or 3kVDC – between power circuit and signal lines RS485 and RS485/RS422	
Optoisolation	~3kVDC - between signal line RS485 (KDU) and RS485/RS422(RTU).	
Electromagnetic compatibility	Resistance it disruptions according to PN-EN 61000-2 norm. Emission of disruptions according to PN-EN 61000-4 norm.	
Safety requiring	According it the PN-EN 61010-1 norm.	
Environment	Industrial	

Environmental Parameters	
Operating temperature	-30 ÷ 60°C
Humidity	5 ÷ 95% - non-condensing
Storage temperature	-40 ÷ 70 °C
Casing	
Dimensions	53 x 90 x 62 mm
Material	Noryl UL. 94 V-O
Degree of casing protection	IP40
Degree of terminal protection	IP20
Weight	0,10 kg
According is a standard	DIN EN50022, DIN EN43880
Position during operation	Free
Mounting	Rail mounting according it is DIN35 standard / TS35.

### Clarifications

\*) - Names of companies and logotypes have been used only for informational purposes.

### Dear Customer,

Thank you for purchasing **CEL-MAR Company** products.

We hope that this user manual helped connect and start up the **ADA-4040PC9 converter**. We also wish to inform you that we are a manufacturer of the widest selections of data communications products in the world such as: data transmission converters with interface RS232, RS485, RS422, USB, Current Loop, Fibre-Optic Converters and Ethernet or Wi-Fi.

Please contact us to tell how you like our products and how we can satisfy you present and future expectation.

### CEL-MAR sp.j.

Zakład Informatyki i Elektroniki  
Ściegiennego 219C Str.  
25-116 Kielce, POLAND

Tel.....: +48 41 362-12-46  
Tel/fax.....: +48 41 361-07-70  
Web.....: <http://www.cel-mar.pl/en>  
Office.....: [office@cel-mar.pl](mailto:office@cel-mar.pl)  
Sales department.....: [sales@cel-mar.pl](mailto:sales@cel-mar.pl)  
Technical information .....: [support@cel-mar.pl](mailto:support@cel-mar.pl)