

User manual

ADA-4021

RS-485 / RS-422 to Current Loop Converter



Contents

1. GENERAL INFORMATION.....	3
1.1. WARRANTED INFORMATION.....	3
1.2. GENERAL CONDITIONS FOR SAFE USE.....	3
1.3. CE LABEL.....	3
1.4. ENVIRONMENTAL PRESERVATION.....	3
1.5. SERVICE AND MAINTENANCE.....	3
1.6. PACK CONTENTS.....	3
2. PRODUCT INFORMATION.....	3
2.1. PROPERTIES.....	3
2.2. DESCRIPTION.....	4
2.3. CURRENT LOOP TRANSMITTER.....	4
2.4. CURRENT LOOP RECEIVER.....	4
2.5. ISOLATION.....	5
3. INSTALLATION.....	5
3.1. ASSEMBLING.....	5
3.2. CONNECTION TO PC.....	5
3.3. CONNECTION TO RS485 BUS.....	6
3.3.1. 4-WIRE CONNECTION.....	6
3.3.2. 2-WIRE CONNECTION.....	6
3.3.3. LINE TERMINATION.....	6
3.4. CONNECTION TO CURRENT LOOP DEVICE.....	7
3.4.1. CONNECTION TO DEVICE WITH PASSIVE TRANSMITTER & PASSIVE RECEIVER.....	7
3.4.2. CONNECTION TO DEVICE WITH ACTIVE TRANSMITTER & ACTIVE RECEIVER.....	7
3.4.3. CONNECTION TO DEVICE WITH ACTIVE TRANSMITTER & PASSIVE RECEIVER.....	8
3.4.4. CONNECTION TO DEVICE WITH PASSIVE TRANSMITTER & ACTIVE RECEIVER.....	8
3.5. POWER SUPPLY CONNECTION.....	8
4. CONFIGURATION.....	8
4.1. SETTING OF OPERATING MODE.....	9
4.2. DEFAULT SETTING.....	9
5. ACTIVATION.....	9
5.1. LEDS DESCRIPTION.....	9
6. VERSIONS.....	9
7. SPECIFICATION.....	10

1. GENERAL INFORMATION

Thank you for your purchase of **CEL-MAR Company** product. This product has been completely tested, and is covered by two-years warranty on parts and operation.

If any questions or problems arise during installation or use of this product, please do not hesitate to contact Technical Support at +48 41 362-12-46 or e-mail support@cel-mar.pl.

1.1. WARRANTED INFORMATION

CEL-MAR Company gives two years guarantee on the **ADA-4021 converter**. The warranty does not cover damage caused from improper use, materials consumption or any unauthorized changes. If the product does not function accordance with the instructions will be repaired. All warranty and no warranty repairs must be returned with paid transport and insuring to the **CEL-MAR Company**.

CEL-MAR Company under no circumstances won't be responsible for ensuing damage from improper using the product or as a result of random causes: the lightning discharge, the flood, the fire and the like.

CEL-MAR Company is not be held responsible for damages and loss including: loss of profits, loss of data, pecuniary losses ensuing from using or the impossibility of using this product.

In specific cases **CEL-MAR Company** discontinue all warranties and in particular do not follow the user manual and do not accept terms of warranty by the user.

1.2. GENERAL CONDITIONS FOR SAFE USE

The device should be installed in a safe and stable places (eg. electroinstallation cabinet), the powering cable should be arranged so as not to be exposed to trampling, attaching, or pulling out of the circuit.

Do not put device on the wet surface.

Do not connect devices for nondescript powering sources,

Do not damage or crush powering wires.

Do not make connection with wet hands.

Do not adapt, open or make holes in casings of the device!

Do not immerse device in water or no other liquid.

Do not put the fire opened on device sources: candles, an oil lamps and the like.

Complete disable from the supply network is only after disconnecting the power supply circuit voltage.

Do not carry out the assembly or disassembly of the device if it is enabled. This may result to short circuit and damage the device.

The device can not be used for applications that determine human life and health (eg. Medical).

1.3. CE LABEL



The CE symbol on the device CEL-MAR means compatibility with electromagnetic compatibility Electromagnetic Compatibility Directive **EMC 2014/30/WE**.

Declaration of Conformity is delivered with purchased device.

1.4. ENVIRONMENTAL PRESERVATION



This sign on the device inform about putting expended device with other waste materials. Device should send to the recycling. (In accordance with the act about the Electronic Appliance Expended from day 29 of July 2005)

1.5. SERVICE AND MAINTENANCE

ADA-4021 converter does not require the servicing and maintenance.

Technical support is available at number +48 41 362-12-46 in 8.00-16.00, from Monday to Friday or e-mail support@cel-mar.pl.

1.6. PACK CONTENTS

ADA-4021 converter; user manual; CE declaration; resistors: $R_t=120\Omega$ (2 pcs).

2. PRODUCT INFORMATION

2.1. PROPERTIES

- Operating on 4-wire network in Current Loop standard
- Operating 2-wire or 4-wire network in RS485 / RS422 standard,
- Possibility of connection up to 32 devices on RS485 / RS422 network
- Baud rate up to 38,4 kbps,
- Transparent for all protocols: MODBUS, DNP, PROFIBUS and other,
- Power supply 10 - 30 VDC stable,
- ~3kV= optoizolation in signal channel between RS485/422 and Current Loop interface,
- 1kV= or 3kV= galvanic isolation between RS485/422 interface and power supply,
- 1kV= or 3kV= galvanic isolation between Current Loop interface and power supply,
- Automatic control of transmitter/receiver of RS485 network,
- Screw terminal block connectors for all connections,
- Integrated short circuit protection and over-voltage protection on RS485/422 lines,
- Integrated short circuit protection and over-voltage protection on Current Loop lines,
- Protection against power supply reverse connection,
- DIN 43880 standard - mounting in typical electro-installation unit,
- Rail mounting according to DIN35 / TS35 standard,
- Dimensions (W x D x H) 53mm x 62mm x 90mm.

2.2. DESCRIPTION

ADA-4021 converts RS485/RS422 standard to Current Loop without interfering with format of transmitted data with maximum baud rate of 38,4kbps via 2-pair of twisted pair.

The converter has screw terminal block for connection of RS485/422, Current Loop networks and power supply. This device use RX+, RX-, TX+, TX- signals for operating.

Over-voltage protection was made on base safety diodes and fuses on each RS485/RS422 and Current Loop lines. It is possible to connect up to 32 devices operate in half duplex mode (inquiry / response) on 2 or 4 wires, multipoint bus or full duplex mode on 4 wires bus, built on the base of ADA-4021 converters. To Current Loop interface can be connected one device in point-to-point topology, operates in half duplex or full duplex mode. Current Loop connected device can has passive or active transmitter and receiver.

This converter has internal, low energy surge protection for each Current Loop lines however it is recommended to use the external lightning arresters (typical protection of telephone line) for the lightning protection of lines.

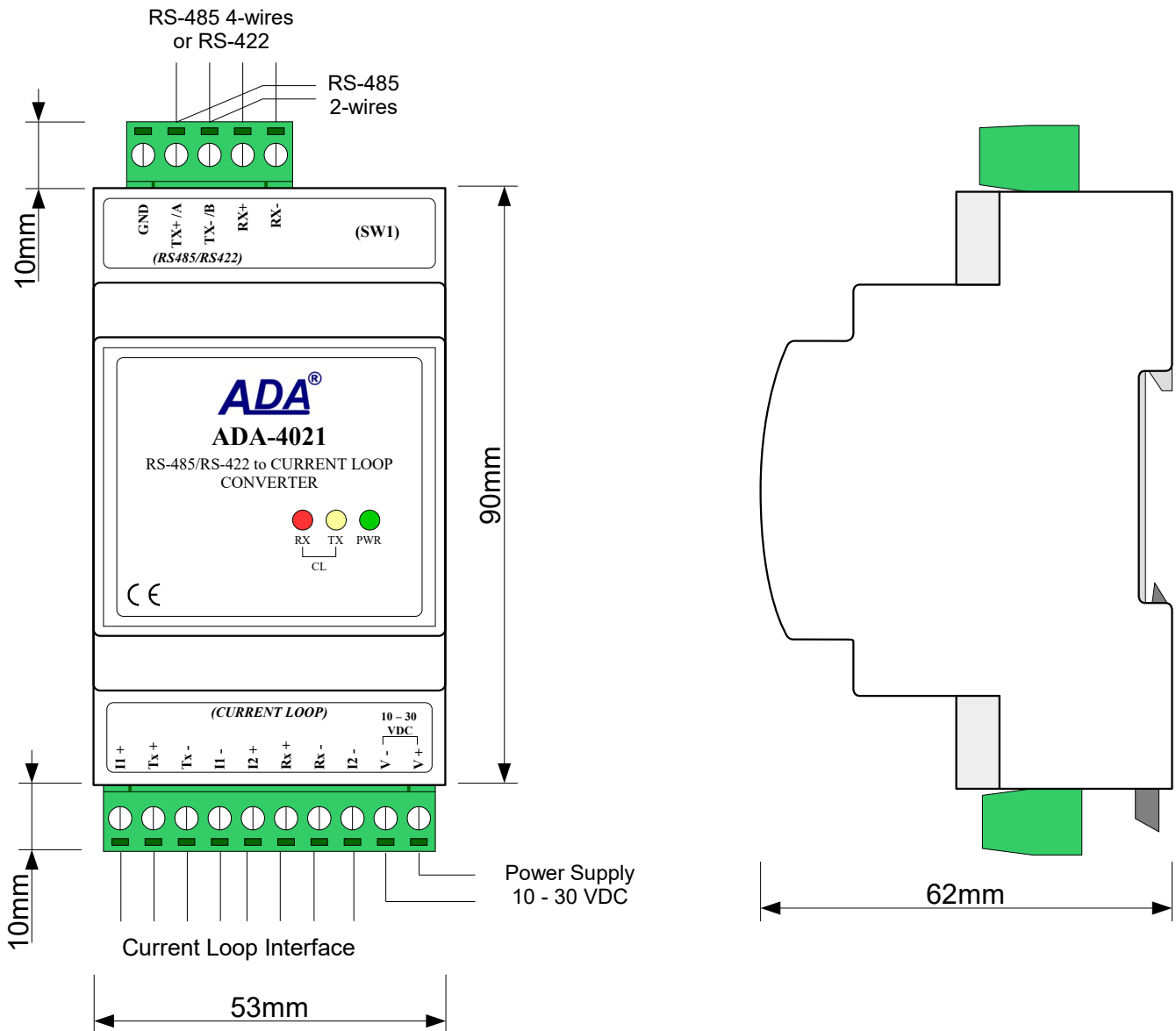

Fig 1. View

2.3. CURRENT LOOP TRANSMITTER

The Current Loop transmitter in the ADA-4021 was made as a passive 0-20mA, having low energy short circuit protection on TX+ and TX- lines. By the correct connection of the transmitter with power source I1, Current Loop transmitter 0-20mA can operate as active. The transmitter diagram is shown on figure below.

2.4. CURRENT LOOP RECEIVER

ADA-4021 converter has passive RX receiver having low energy short circuit protection on TX+ and TX- lines.

By the correct connection of the receiver with power source I2, Current Loop receiver 0-20mA can operate as active.

The RX red LED on front panel of the converter is a signalization of NO current flow through optocoupler. This LED is ON when it is:

- not connect transmitter to receiver,
- wrong connection of transmitter to receiver,
- broken connection of transmitter to receiver.

The diagram is shown on figure below.

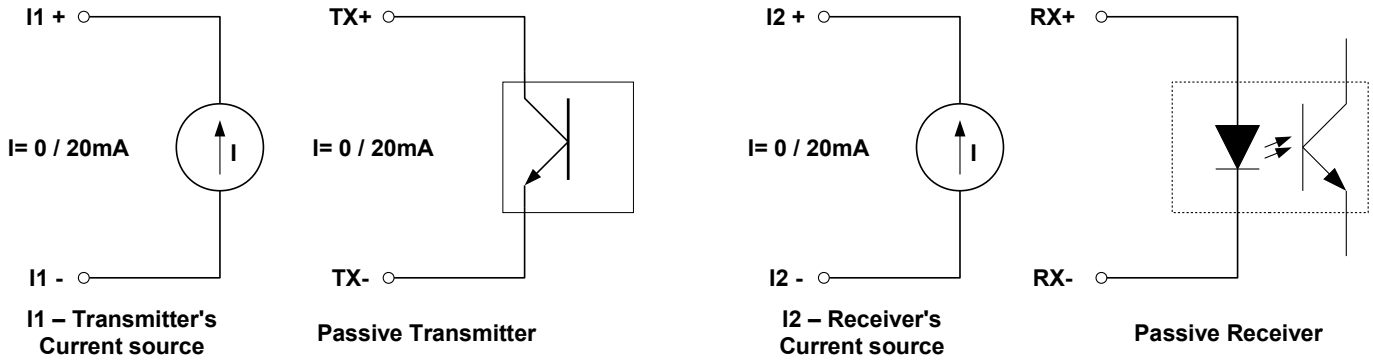

Fig 2. Diagram of the transmitter & receiver ADA-4021 Current Loop

2.5. ISOLATION

Converter ADA-4021 has 3-way galvanic isolation on level 1kV= or 3kV=, depend on version described in section below.

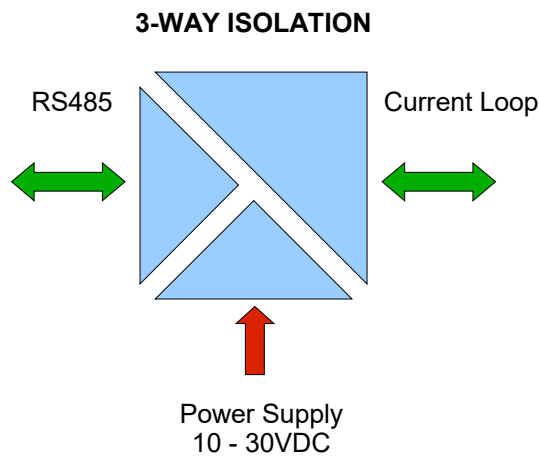

Fig 3. Isolation structure

3. INSTALLATION

This chapter will show how to connect ADA-4021 to PC, Current Loop bus, RS485/422 bus and power supply and how to use it. In the purpose of minimization of disruptions from environment is being recommended to:

- apply multipair type shielded cables, which shield can be connected to the earthing on one end of the cable,
- arrange signal cables in the distance not shorter than 25 cm from powering cables,
- apply cable of adequate cross-section due to voltage drops for converter powering,
- use Interference suppression filters for power supply converters that are installed within a single object.
- not supply converter from power circuit device that generates large impulse interference such as transmitters, contactors,

3.1. ASSEMBLING

The ADA-4021 enclosure is adapted to assembly on TS-35 (DIN35) rail. To install converter should the upper part of casing hang hooks on the rail, than push the lower part until to hearing characteristic "Click" sound.

3.2. CONNECTION TO PC

To connect the ADA-4021 converter to computer RS232 port should be used additional converter eg RS232 to RS485 ADA-I1040. This converter should be connected with ADA-4021 via RS485 or RS422 bus as shown on the example figure below.

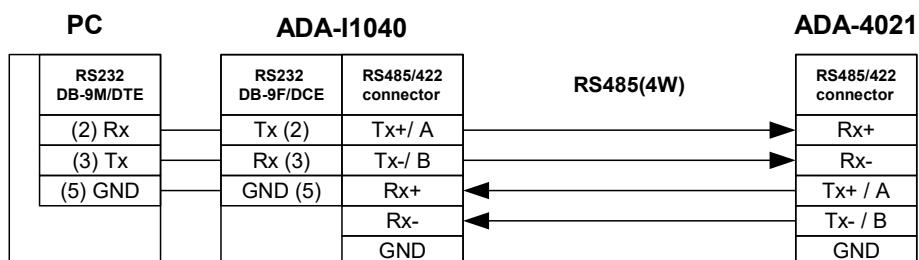

Fig 4. Connection to PC by the use of RS232 to RS485/422 converter ADA-I1040 – 4-wires RS485

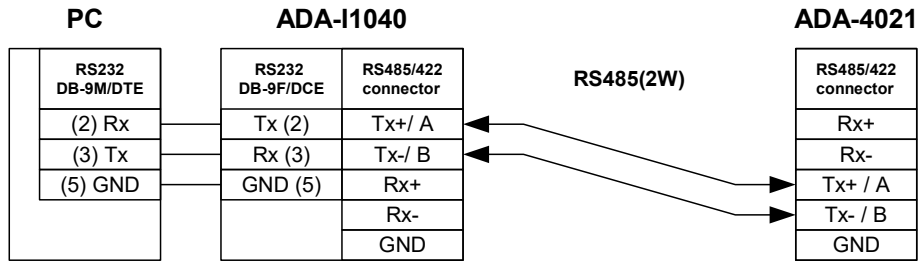

Fig 5. Connection to PC by the use of RS232 to RS485/422 converter ADA-I1040 – 2-wires RS485

3.3. CONNECTION TO RS485 BUS

RS485/422 interface at ADA-4021 converter is available on terminal block described as: Tx+/A, Tx-/B, Rx+, Rx-. Types of connection the ADA-4021 converter to RS485(4W)/RS422 and RS485(2W) bus are shown below.

3.3.1. 4-WIRE CONNECTION

After connection devices according to figure below, the converter should be set for operating on RS485 bus – see pt. 4.1.

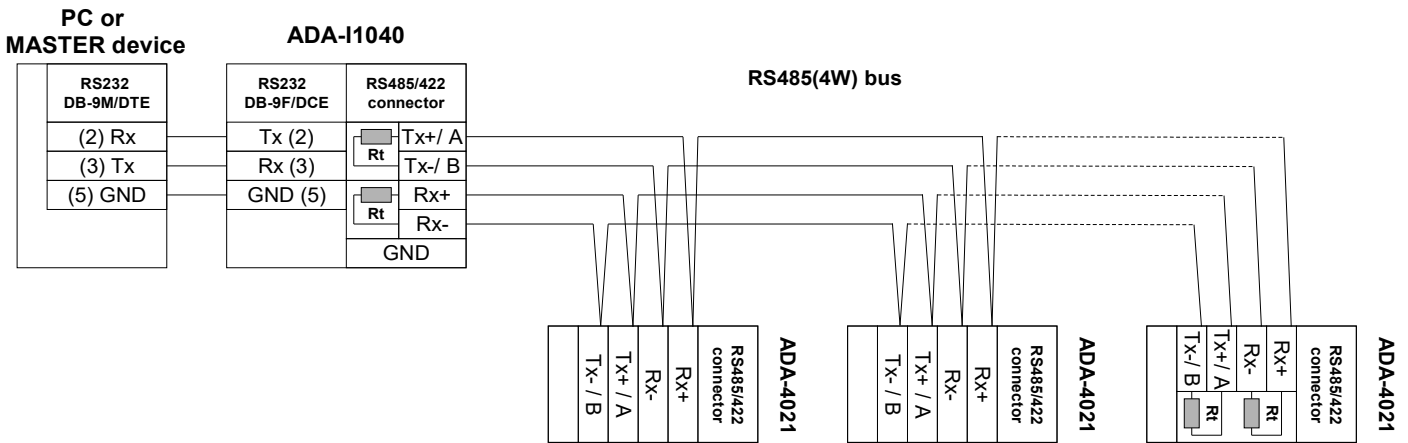

Fig 6. Example connection to RS485 4-wires bus

3.3.2. 2-WIRE CONNECTION

After connection devices according to figure below, the converter should be set for operating on RS485 bus – see pt. 4.1.

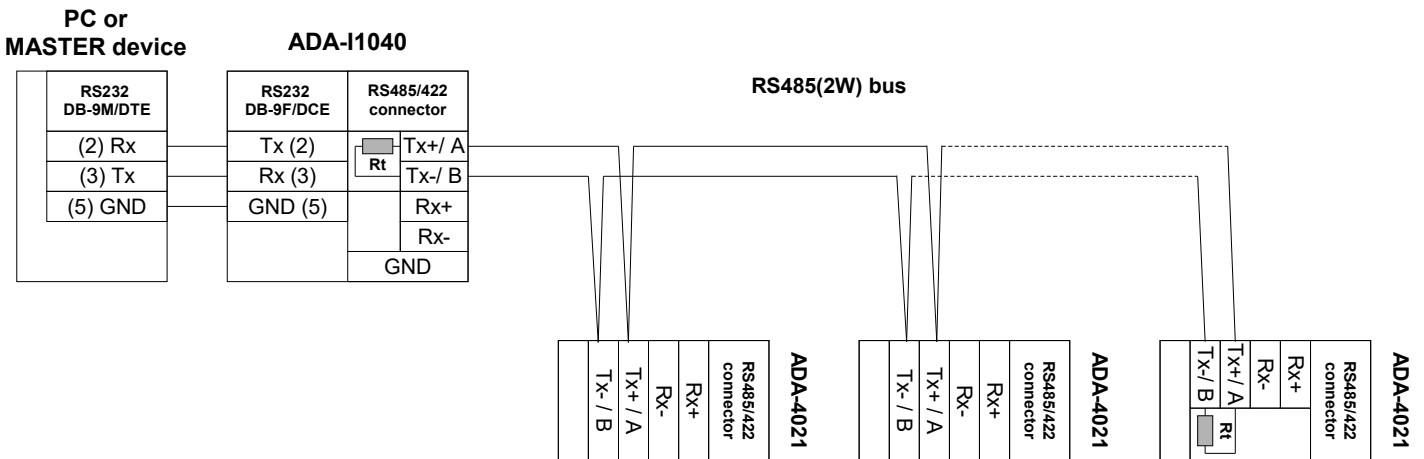

Fig 7. Example connection to RS485 2-wires bus

3.3.3. LINE TERMINATION

The application of Line Termination (terminator) $R_t = 120 \Omega$ will reduce electrical reflection in data line at high baud rate. It is not needed below 9600Bd, should be used the Line Termination resistor if the distance is over 1000m @ 9600Bd or 700m @ 19200Bd transmission. Example connection of R_t are shown on Fig. 6 & 7. Two resistors $R_t = 120\Omega$, 5%, 0,25W are supplied with ADA-4021 converter, free of charge.

3.4. CONNECTION TO CURRENT LOOP DEVICE

Current Loop line is connected to TX+, TX-, I1+, I1-, RX+, RX-, I2+, I2- terminals of converter as below.

3.4.1. CONNECTION TO DEVICE WITH PASSIVE TRANSMITTER & PASSIVE RECEIVER

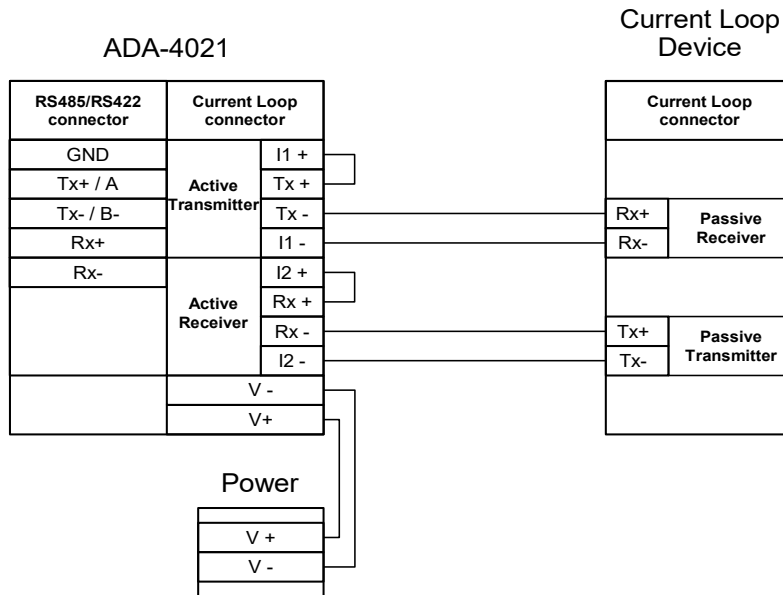

Fig 8. Example connection of device with passive transmitter and passive receiver to ADA-4021

3.4.2. CONNECTION TO DEVICE WITH ACTIVE TRANSMITTER & ACTIVE RECEIVER

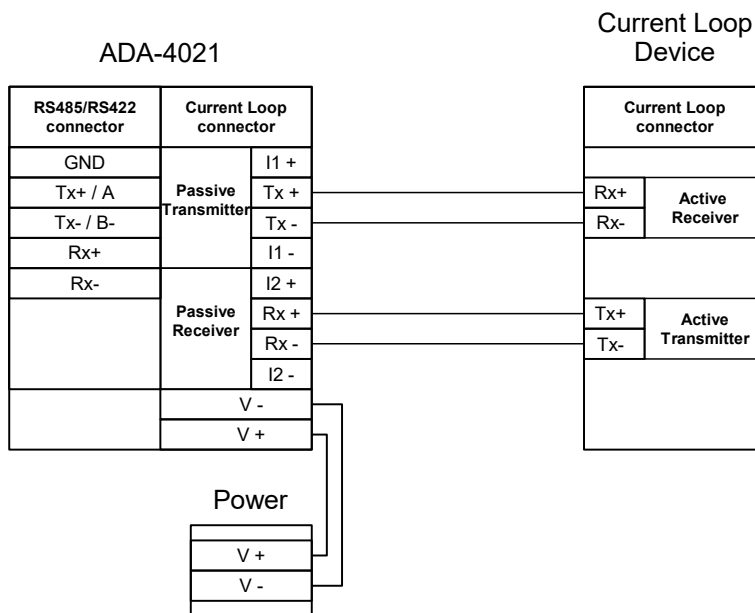

Fig 9. Example connection of device with active transmitter and active receiver to ADA-4021

3.4.3. CONNECTION TO DEVICE WITH ACTIVE TRANSMITTER & PASSIVE RECEIVER

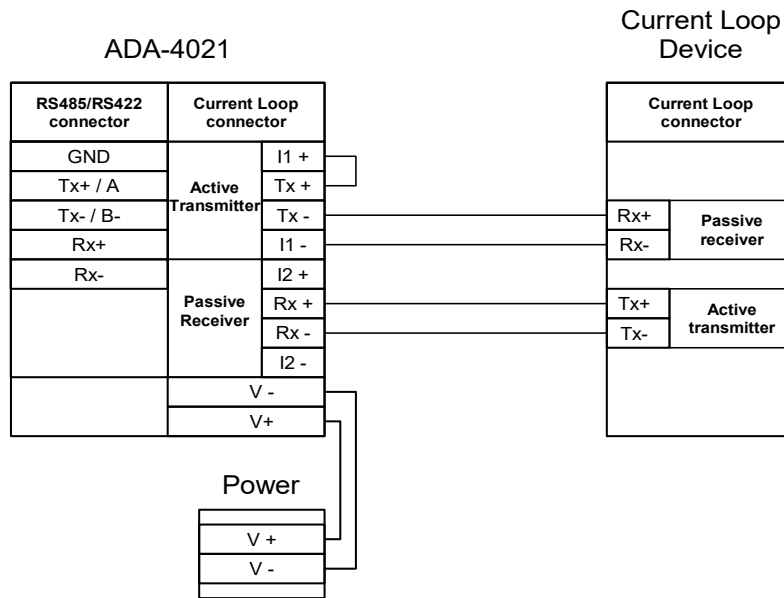

Fig 10. Example connection of device with active transmitter and passive receiver to ADA-4021

3.4.4. CONNECTION TO DEVICE WITH PASSIVE TRANSMITTER & ACTIVE RECEIVER

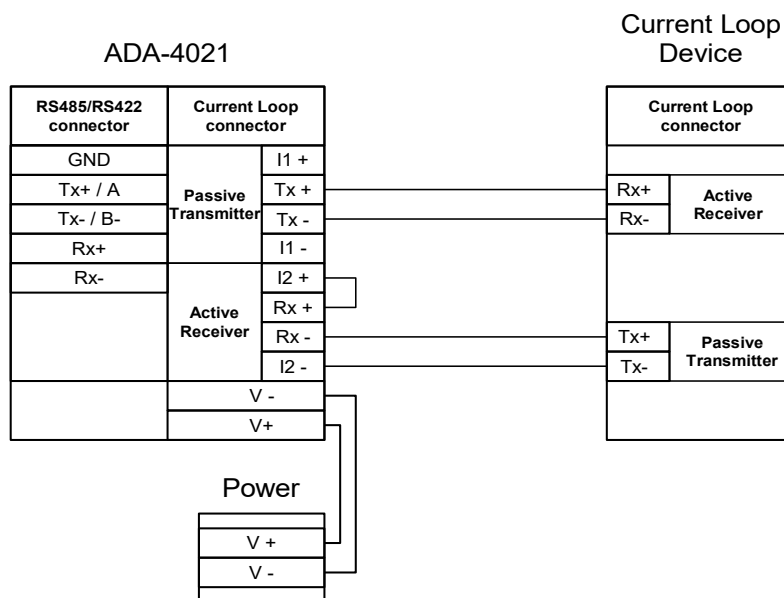

Fig 11. Example connection of device with passive transmitter and active receiver to ADA-4021

3.5. POWER SUPPLY CONNECTION

The power supply to the ADA-4021 converter should be DC (regulated) from 10 V= to 30V=. Nominal power is typically 2W, e.g. HDR-15-24. Power cable from DC power supplies to device must not be longer than 3m. Observe the polarity, connect positive (+) of DC power supplies to V+ and negative (-) end to V- terminal. ADA-4021 has the protection from opposite connection power supply.

4. CONFIGURATION

The operating mode of the ADA-4021 converter is set by the use 6-position SW1 switch. This switch is located near the five-pin screw terminal block (see Fig.1). To set the SW1 should remove the terminal cover and using small, flat screwdriver make correct setting.

4.1. SETTING OF OPERATING MODE

All available operating modes are shown in table below.

If there are any additional questions, please contact with technical support: support@cel-mar.pl or on the phone: +48 41 362-12-46.

Table 1. RS422 or RS485 operating mode.

SW1-1	SW1-2	SW1-3	SW1-4	SW1-5	SW1-6	Description	Operating mode
OFF	OFF	OFF	OFF	OFF	OFF	RS-422 bus	4-wire RS422 network. Full duplex or half duplex transmission.
ON	ON	ON	ON	ON	ON	RS-485 bus, automatic data flow control	2-wire and 4-wire RS485 network. Full duplex or half duplex transmission.

4.2. DEFAULT SETTING

The ADA-4021 converter is being set in RS485 mode during production as in the table below.

Table 2.

SW1-1	SW1-2	SW1-3	SW1-4	SW1-5	SW1-6
ON	ON	ON	ON	ON	ON

5. ACTIVATION

Converter can be powered after proper connection according to steps above.

If connection was made properly green LED PWR on front panel of converter should light, if not check polarization of power connection. If the red LED RX is light check correctness of connection transmitting line of Current Loop Device. The lighting of RX LED indicates no current flow through the optocoupler in the receiver's circuit.

During proper data transmission through converter the LEDs Tx and Rx should blink.

5.1. LEDS DESCRIPTION

LED	Description
PWR	Signalization of Power Supply
RX	Signalization of data receiving by ADA-4021 from Current Loop.
TX	Signalization of data transmission from ADA-4021 converter through Current Loop

6. VERSIONS

ADA-4021 -					
Electronics version:					
Standard		1			
Current Loop Voltage:					
24VDC			1		
12VDC (standard)			2		
Current Loop Current:					
0 – 20 mA (standard)				1	
0 – 30 mA				2	
Galvanic isolation:					
1kV= 3-way					2
3kV= 3-way					3

Order example:

Product symbol: **ADA-4021-1-2-1-2**

- 1 – standard electronics version,
- 2 – current loop voltage 12VDC,
- 1 – current loop current 0-20mA,
- 2 – galvanic isolation 1kV=,

7. SPECIFICATION

TECHNICAL DATA
Transmission Parameters

Interface	RS-485/RS-422	Current Loop
Connector	Screw terminal, wire max. Ø 2,5mm ² .	Screw terminal, wire max. Ø 2,5mm ² .
Line length	up to 1200 m	Depend on baud rate, several kilometres
Maximum number of connected device	up to 32	1
Transmission line	1-pair, 2-pair twisted cable eg UTP Nx2x0,5(24AWG), shield inside large interferences eg STP Nx2x0,5(24AWG)	2-pair twisted cable eg UTP Nx2x0,5 (24AWG), shield inside large interferences eg STP Nx2x0,5 (24AWG).
Standards	EIA-485, CCITT V.11	0-20mA Current Loop
Maximum baud rate	38,4 kbps (depend on length of Current Loop line)	
Transmission type	Asynchronous half duplex or full duplex	
Optical signalization	<ul style="list-style-type: none"> • PWR – green LED power supply, • RX - red LED data receiving from Current Loop side, • TX - yellow LED data transmission through Current Loop interface. 	

Electrical Parameters

Power requirements	10 - 24 – 30 V DC
Power cable	Recommended length of power cable < 3m
Power	2W
Protection from reverse power polarization	YES
Galvanic isolation	1kV= or 3kV= between power circuit and Current Loop signal line and RS485/422
Optoisolation	~3kVDC between Current Loop signal line and RS485/422
Electromagnetic compatibility	Resistance to disruptions according to the standard PN-EN 55024. Emission of disruptions according to the standard PN-EN 55022.
Safety requiring	According to the PN-EN60950 norm.
Environment	Commercial and light industrial.

Environmental Parameters

Operating temperature	-30 ÷ 60°C
Humidity	5 ÷ 95% - non-condensing
Storage temperature	-40 ÷ 70°C

Casing

Dimensions	53 x 90 x 62mm
Material	PC/ABS
Degree of casing protection	IP40
Degree of terminal protection	IP20
Weight	0,10 kg
According to standards	DIN EN50022, DIN EN43880
Location during work	Free
Mounting method	On the rail compliant with DIN35 / TS35 standard.

Dear Customer,

Thank you for purchasing **CEL-MAR Company** products.

We hope that this user manual helped connect and start up the **ADA-4021 converter**. We also wish to inform you that we are a manufacturer of the widest selections of data communications products in the world such as: data transmission converters with interface RS232, RS485, RS422, USB, Current Loop, Fibre-Optic Converters and Ethernet or Wi-Fi.

Please contact us to tell how you like our products and how we can satisfy you present and future expectation.

CEL-MAR sp.j.

Zakład Informatyki i Elektroniki
Sciegennego 219C str.
25-116 Kielce, POLAND

Tel.....: +48 41 362-12-46
Tel/fax.....: +48 41 361-07-70
Web.....: <http://www.cel-mar.pl/en>
Office.....: office@cel-mar.pl
Sales department.....: sales@cel-mar.pl
Technical information: support@cel-mar.pl