

User manual

ADA-1040PC4

AquaMatic to MODBUS-RTU converter



Contents

1. GENERAL INFORMATION.....	3
1.1. WARRANTED INFORMATION.....	3
1.2. GENERAL CONDITIONS FOR SAFE USE.....	3
1.3. CE LABEL.....	3
1.4. ENVIRONMENTAL PRESERVATION.....	3
1.5. SERVICE AND MAINTENANCE.....	3
1.6. PACK CONTENTS.....	3
2. PRODUCT INFORMATION.....	3
2.1. PROPERTIES.....	3
2.2. DESCRIPTION.....	4
2.3. SUPPORTED RAINWATER CONTROL PANELS.....	4
2.4. ISOLATION.....	5
3. INSTALLATION.....	5
3.1. ASSEMBLING.....	5
3.2. CONNECTION TO COMPUTER.....	5
3.3. CONNECTION TO RS232 INTERFACE OF RCU AQUAMATIC INDUSTRIAL.....	6
3.4. CONNECTION TO RS485/RS422 BUS.....	6
3.4.1. CONNECTION OF RCU AQUAMATIC INDUSTRIAL TO RS485(4W) MODBUS-RTU BUS.....	6
3.4.2. CONNECTION OF RCU AQUAMATIC INDUSTRIAL TO RS485(2W) MODBUS-RTU BUS.....	7
3.4.3. GND TERMINAL CONNECTION.....	7
3.4.4. LINE TERMINATION Rt.....	7
3.5. POWER SUPPLY CONNECTION.....	7
4. ACTIVATION.....	7
4.1. DESCRIPTION OF SIGNALLING LEDES.....	7
4.2. TROUBLESHOOTING.....	8
5. CONFIGURATION.....	8
5.1. OPERATION MODES.....	8
5.2. CONFIGURATION BY USING ADACONFIG.....	8
5.3. FIRMWARE UPDATE.....	9
5.4. EMERGENCY FIRMWARE UPDATE.....	10
5.5. FACTORY DEFAULT.....	10
6. DATA TRANSMISSION DIAGNOSTICS.....	10
7. OPERATION.....	11
8. IMPLEMENTATION OF MODBUS-RTU PROTOCOL.....	11
8.1. TABLE OF MODBUS-RTU ADDRESSES.....	11
8.1.1. REGISTERS ACTUAL VALUE RCU AQUAMATIC INDUSTRIAL PARAMETERS, READOUT BY FUNCTION 04 (3X – REFERENCES) INPUT REGISTERS.....	11
8.1.2. REGISTERS ACTUAL VALUE RCU AQUAMATIC INDUSTRIAL PARAMETERS, READOUT BY FUNCTION 03 (4X – REFERENCES) HOLDING REGISTERS.....	12
8.2. FRAME STRUCTURE OF MODBUS-RTU PROTOCOL.....	14
8.3. USED FUNCTIONS OF MODBUS-RTU PROTOCOL.....	14
8.3.1. FUNCTION 0x03 / 0x04 - READING RCU AQUAMATIC INDUSTRIAL PARAMETER VALUES.....	14
8.3.1.1. READING OF CURRENT PARAMETER VALUE, STORED IN 16-BIT REGISTER [4X / 3X-REFERENCES].....	14
9. 9. RS232 INTERFACE – PIN DESCRIPTION OF DB-9F SOCKET.....	15
10. VERSIONS.....	15
11. SPECIFICATION.....	16

Comments:

RCU – Rainwater Control Unit;

*) - Names of companies and logotypes have been used only for informational purposes.

1. GENERAL INFORMATION

Thank you for your purchase of **CEL-MAR** company product. This product has been produced and completely tested by us.

If any questions or problems arise during installation or use of this product, please do not hesitate to contact Technical Support at +48 41 362-12-46 or e-mail support@cel-mar.pl.

1.1. WARRANTED INFORMATION

The **ADA-1040PC4** converter is covered by a two year warranty from date of sale. In case of being damaged it will be repair or the damaged component will be replace. The warranty does not cover damage caused from improper use, materials consumption or any unauthorized changes. If the product does not function (is damaged), or not operate in accordance with the instructions, will be repaired or replaced.

All warranty and no warranty repairs must be returned with paid transport and insuring to the **CEL-MAR Company**.

CEL-MAR Company under no circumstances won't be responsible for ensuing damage from improper using the product or as a result of random causes: the lightning discharge, the flood, the fire and the like.

CEL-MAR Company is not be held responsible for damages and loss including: loss of profits, loss of data, pecuniary losses ensuing from using or the impossibility of using this product.

In specific cases **CEL-MAR Company** discontinue all warranties and in particular do not follow the user manual and do not accept terms of warranty by the user.

1.2. GENERAL CONDITIONS FOR SAFE USE

The device should be installed in a safe and stable places (eg, electroinstallation cabinet), the powering cable should be arranged so as not to be exposed to trampling, attaching, or pulling out of the circuit.

Do not put device on the wet surface.

Do not connect devices for nondescript powering sources,

Do not damage or crush powering wires.

Do not make connection with wet hands.

Do not adapt, open or make holes in casings of the device!

Do not immerse device in water or no other liquid.

Do not put the fire opened on device sources: candles, an oil lamps and the like.

Complete disable from the supply network is only after disconnecting the power supply circuit voltage.

Do not carry out the assembly or disassembly of the device if it is enabled. This may result to short circuit and damage the device.

The device can not be used for applications that determine human life and health (eg. Medical).

1.3. CE LABEL



The CE symbol on the device **CEL-MAR** means compatibility with electromagnetic compatibility Electromagnetic Compatibility Directive **EMC 2014/30/WE**. Declaration of Conformity is available by contact with Technical Service (email: support@cel-mar.pl; phone: +48 41 362-12-46).



1.4. ENVIRONMENTAL PRESERVATION

This sign on the device inform about putting expended device with other waste materials. Device should send to the recycling. (In accordance with the act about the Electronic Appliance Expended from day 29 of July 2005)

1.5. SERVICE AND MAINTENANCE

The ADA-1040PC4 converter does not require the servicing and maintenance.

Technical support is available at number +48 41 362-12-46 in 8.00-16.00, from Monday to Friday or e-mail support@cel-mar.pl.

1.6. PACK CONTENTS

ADA-1040PC4 converter, User Manual; CE declaration, line terminators resistors: $R_t=120\Omega$ (2 pcs.).

2. PRODUCT INFORMATION

2.1. PROPERTIES

- Conversion of protocols AquaMatic (RS232) to MODBUS-RTU (RS485/RS422),
- Parameters, baud rate and data format conversion between RS485/RS422 and RS232 converter's ports,
- Operating on 2 or 4 wire buses in RS485/RS422 standard in point-to-point and multipoint mode,
- Conversion TX, RX signals of RS232 standard to RS485/RS422 standard and inversely,
- Operation up to 32 devices on RS485 bus,
- Baud rate set on RS232 & RS485/RS422 interfaces (bps): 300, 600, 1200, 1800, 2400, 4800, 7200, 9600, 14400, 19200, 28800, 38400, 57600, 76800, 115200, 230400,
- Data format set on RS232 & RS485/RS422 interfaces: data bit: 5, 6, 7, 8; parity: None, Odd, Even; number of stop bits: 1, 2,
- Power supply 10 - 30 VDC stable min. 2W,
- ~3kV= optoisolation in signal channel between RS232 and RS485/422 interfaces,
- 1kV= or 3kV= galvanic isolation between RS232 & RS485/422 interfaces and power supply (depend on version),
- Implemented short circuit protection and over-voltage protection on RS485 / RS422 network,
- Implemented ESD 15kV surge protector of RS232 interface,
- Connection RS485/RS422 network and power supply via screw terminal block 2.5 mm².
- DB-9F connector for cable connection of RS232 interface to PC, controller etc.
- Cover compatible with DIN 43880 standard– mounting in typical electro-installation unit,
- Cover adapt to rail mounting according to DIN35 / TS35 standard,
- Cover dimensions (W x D x H) 53mm x 63mm x 90mm,

2.2. DESCRIPTION

Protocol converter **AquaMatic/SP100 to MODBUS-RTU ADA-1040PC4** is a device solves a problem of connection the **RCU** (rainwater control unit) AquaMatic Industrial, equipped with RS232 interface and communicate by **AquaMatic protocol** to multipoint RS-485 bus with devices communicate by **MODBUS-RTU protocol**.

Simultaneously, the converter convert **RS232 to RS485/422** standards, with setting of data formats. Depending on configurations, can be set baud rate, data bits, parity, number of stop bits. The setting can be different for RS232 and RS485/RS422 port.

The converter does not require power supply from RS232 port and support the asynchronous transmission data with baud rate 230,4 kbps.

The **ADA-1040PC4** has DB-9F connector for connecting RS-232 interface of **RCU AquaMatic** and screw terminal block for connection of **RS-485/422** bus and power supply. The DB-9F connector is DCE type to connecting RS232 interface.

The **ADA-1040PC4** uses Tx, Rx and GND signals for communication with RS232 interface.

Overvoltage protection was made on base safety diodes and fuses on each RS485/RS422 lines.

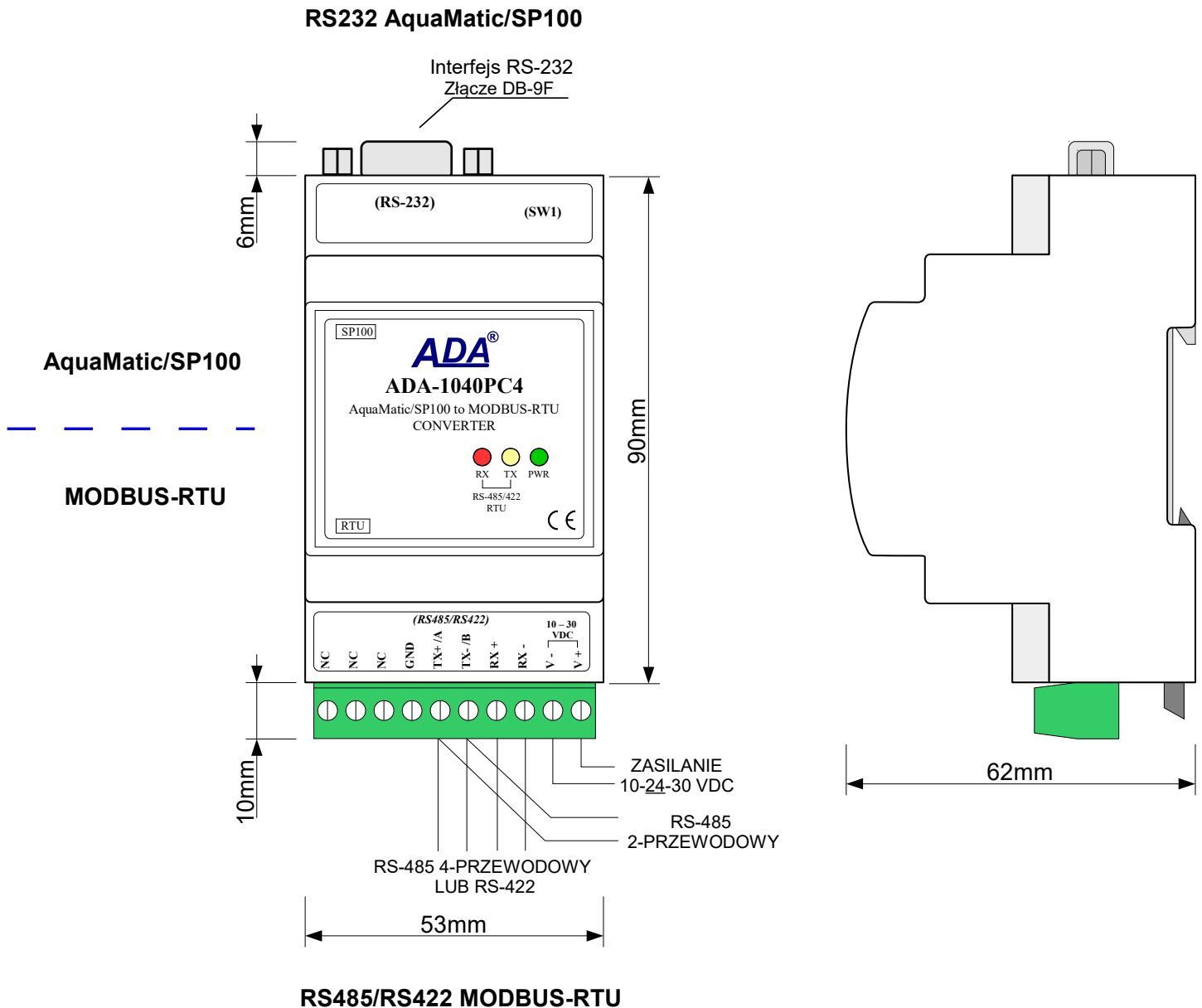

Fig. 1. ADA-1040PC4 view and location of SW1

2.3. SUPPORTED RAINWATER CONTROL PANELS

The ADA-1040PC4 converter supports Rainwater Control Units like:

- a/ AquaMatic Industrial 75
- b/ AquaMatic Industrial 100

2.4. ISOLATION

The ADA-1040PC4 protocol converter has 3-way galvanic isolation on the level 1kV= or 3kV= depend on version, described in section **VERSIONS**.

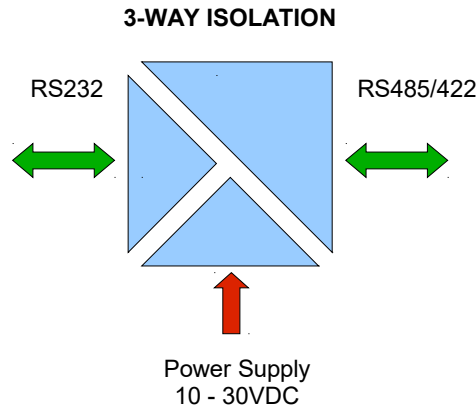

Fig. 2. Isolation structure

3. INSTALLATION

This chapter will show how to use and connect ADA-1040PC4 to RCU AquaMatic Industrial, RS485 / RS422 bus and power supply. In the purpose of minimization of disruptions from environment is being recommended to:

- apply multipair type shielded cables, which shield can be connected to the earthing on one end of the cable,
- arrange signal cables in the distance not shorter than 25 cm from powering cables,
- apply cable of adequate cross-section due to voltage drops for converter powering,
- use suppression filters for powering converters that are installed within a single object,
- not supply converter from power circuit device that generates large impulse interference such as transmitters, contactors.

3.1. ASSEMBLING

The cover of ADA-1040PC4 converter is adapted to assembly on TS-35 (DIN35) rail. To install the converter, should be mounted on the rail upper part of the cover, then press bottom part to hear characteristic „Click” sound.

3.2. CONNECTION TO COMPUTER

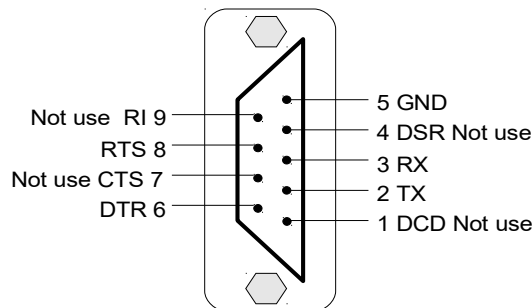

Fig. 3. RS232 interface signals of DB-9F (female) connector.

In case of connection the ADA-1040PC4 converter to:

- RS232 computer port, should be made a cable according to diagram on Fig.4,
- USB computer port, should be used additional converter USB to RS232 (eg. ADA-I9211 or ADA-I9110), which connect to RS232 port of ADA-1040PC3 as on diagram Fig.5.

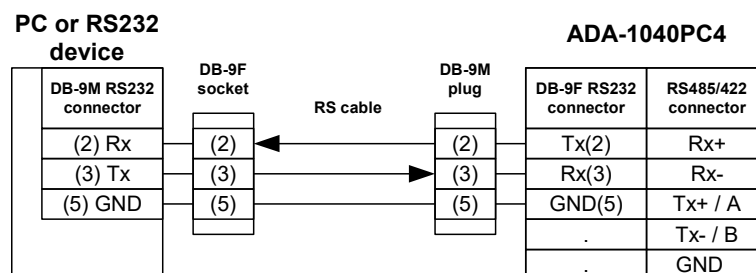

Fig. 4. ADA-1040PC4 connection to PC or RS232 device by the use of the cable.

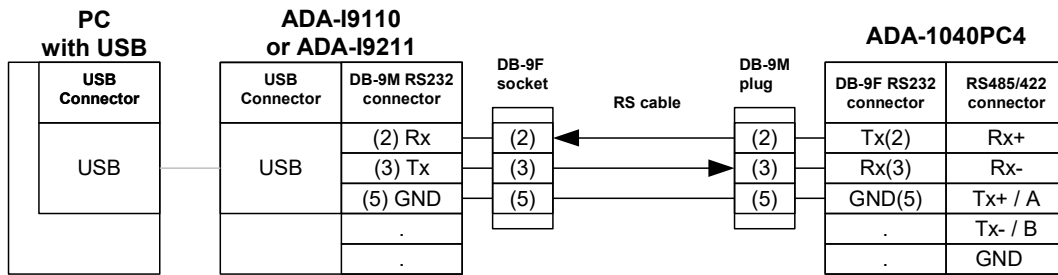

Fig. 5. ADA-1040PC4 connection to PC by the use of additional converter USB to RS232 (ADA-I9211 or ADA-I9110).

3.3. CONNECTION TO RS232 INTERFACE OF RCU AQUAMATIC INDUSTRIAL

In case of connection the ADA-1040PC4 converter to communication port RS232 of RCU AquaMatic Industrial controller, should be done the cable according to diagram on fig. below.

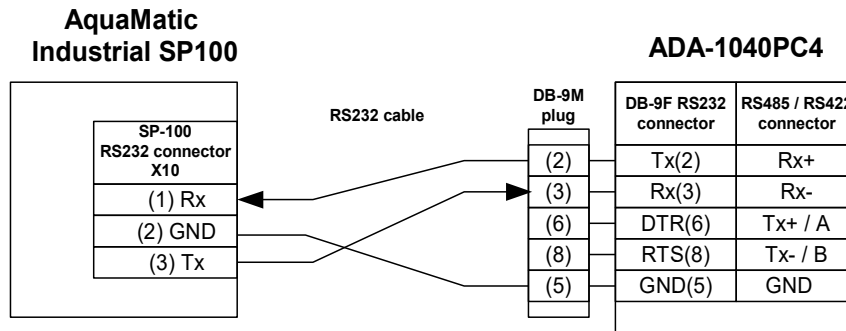

Fig.6. ADA-1040PC4 connection to RS232 port of RCU AquaMatic Industrial.

3.4. CONNECTION TO RS485/RS422 BUS

RS485/RS422 interface in the ADA-1040PC4 converter is available on screw terminal block and is described as: Tx+/A, Tx-/B, Rx+, Rx-, GND.

Connection of the ADA-1040PC4 to RS485(4W) and RS485(2W) bus, are shown below.

3.4.1. CONNECTION OF RCU AQUAMATIC INDUSTRIAL TO RS485(4W) MODBUS-RTU BUS

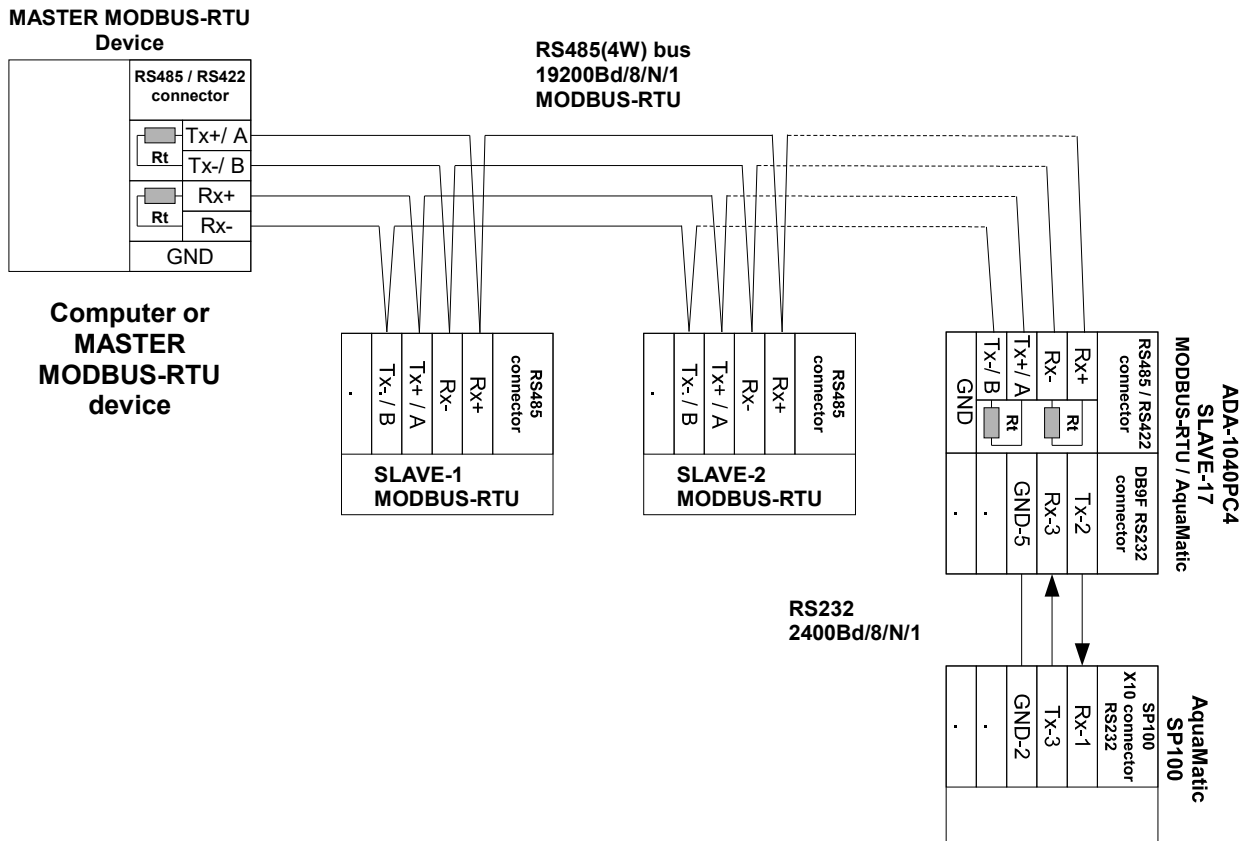

Fig 7. Example connection of RCU AquaMatic Industrial by the use of ADA-1040PC4 to RS485(4W) 4-wire bus.

3.4.2. CONNECTION OF RCU AQUAMATIC INDUSTRIAL TO RS485(2W) MODBUS-RTU BUS

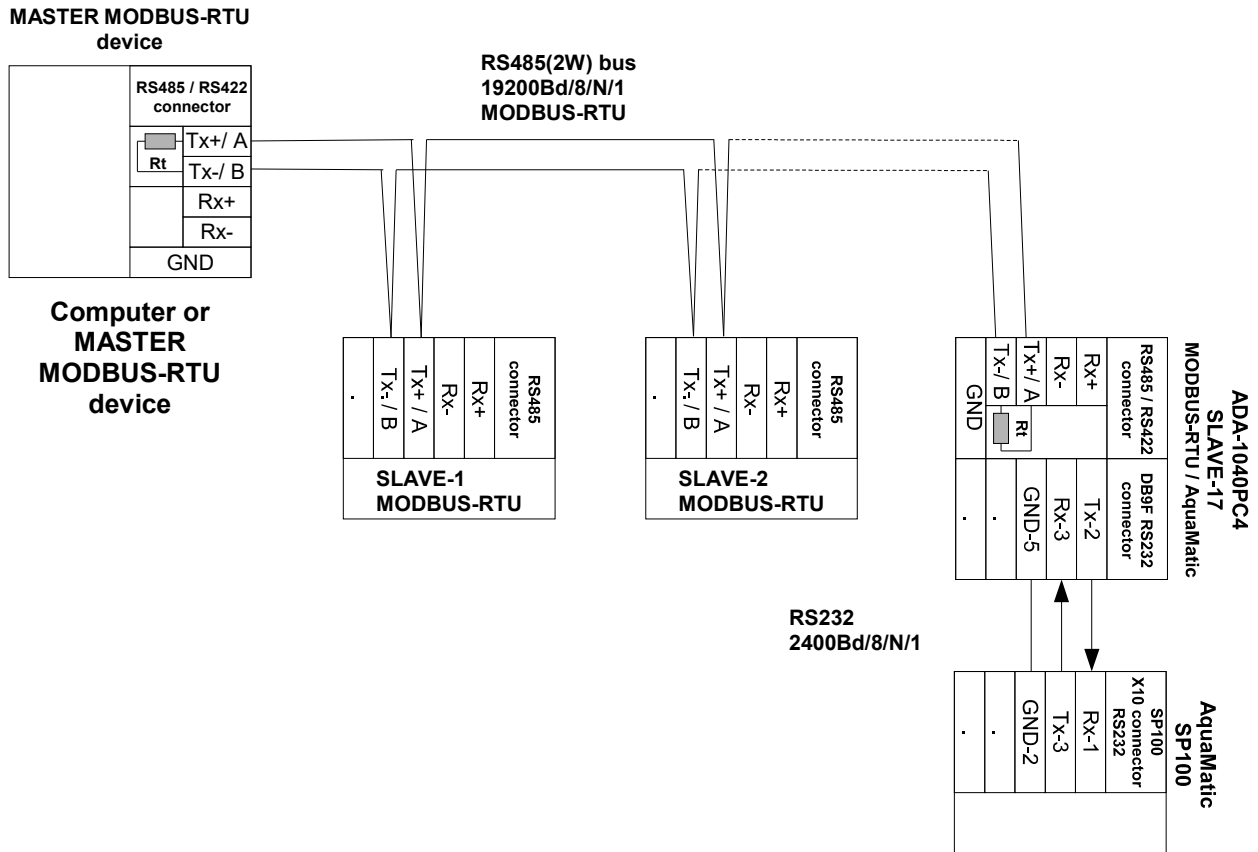

Fig. 8. Example connection of RCU AquaMatic Industrial by the use of ADA-1040PC4 to RS485(2W) 2-wire bus.

3.4.3. GND TERMINAL CONNECTION

Connection of GND terminals of RS485/422 interfaces, devices connected to RS485/422 bus, should be done in the case of a potential difference of the signals grounds on interfaces RS485 / RS422, which prevents proper data transmission.

Cannot connect to the GND terminal - cables screens, PE circuit of electrical installation, signals grounds of other devices.

3.4.4. LINE TERMINATION Rt

The application of Line Termination (terminator) $R_t = 120$ ohms will reduce electrical reflection in data line at high baud rate. It is not needed below 9600Bd. Should be used the Line Termination resistor if the distance is over 1000m @ 9600Bd or 700m @ 19200Bd, and if the disturbance in transmission will appear.

Example connection of R_t are shown on figures above. Two $R_t = 120 \Omega$, 5%, 0,25W are delivered with the converters.

3.5. POWER SUPPLY CONNECTION

To connect power supply to the converter, should have DC power supplies (regulated) output voltage from 10 V= to 30V=, min. nominal power 2W, e.g. HDR-15-24. Power cable from DC power supplies to device can not be longer than 3m.

Should connect positive (+) end of DC power supplies to V+ device terminal and negative (-) end to V- on terminal block.

The ADA-1040PC4 has protection against power supply reverse connection.

4. ACTIVATION

The converter can be power on after properly connection according to section above.

If after connection power supply on front panel will not light green led PWR, check correctness of power supply connecting (polarization). When data is present the LEDs Tx and Rx should blink.

ATTENTION!
AT BAUD RATE ABOVE 38.4 KBPS THE LED'S TX, RX WILL LIGHT WEAKLY DURING DATA TRANSMISSION

4.1. DESCRIPTION OF SIGNALLING LEDS

LED	Opis
PWR	Signalling of Power Supply
RX	Signalling of data receiving through ADA-1040PC4 from RS485/RS422 port – MODBUS-RTU
TX	Signalling of data transmitting from ADA-1040PC4 through RS485/RS422 port – MODBUS-RTU
Yellow LED by SW1	Not light – signalling of normal operating mode (RUN)
	Blinking at frequency 1 Hz - signalling of configuration mode or software data flowing to the converter
	Blinking at frequency 2 Hz - signalling of factory default mode
	Lit continuously – signalling of emergency firmware update

4.2. TROUBLESHOOTING

Problem	Solutions
PWR LED is not light	Check polarization and parameters of connected power supply.
Rx LED lights continuously	RS485(4W) /422 network. Wrong polarization on terminals: Rx+, Rx-; change polarization.
No transmission Tx LED is blinking	RS485(4W) / RS422 network. Check correctness of connection to terminals Tx, Rx; according to point 3 and the converter configuration.

5. CONFIGURATION

5.1. OPERATION MODES

The ADA-1040PC4 converter can operate in a few modes :

- run,
- configuration,
- factory default,
- emergency firmware update

Those modes can be set by use SW1 located by DB-9F connector, labelled as RS232. To set the switch section, should remove the cover marked as SW1 and make the appropriate settings by the use a small, flat screwdriver.

All available adjusting the SW1 switch are shown in table below.

Converter operation modes

SW1- 1	SW1- 2	Mode
OFF	OFF	Run
ON	OFF	Configuration
OFF	ON	Factory default Turning OFF and ON the power of the converter, the configuration will be set to factory default.
ON	ON	Emergency Firmware Update

5.2. CONFIGURATION BY USING ADACONFIG

The configuration of the ADA-1040PC4 protocol converter should be made by the use of **ADAConfig** Software, which should be download from website of **ADA-1040PC4** converter (www.cel-mar.pl/en/rs232_rs485rs422_aqma_rtu_1040pc4.htm), tab **Download**, and then extract **adaconfig.zip** file and run **setup.exe**.

After installation ADAConfig software is available in menu **Win10 Start > CEL-MAR > ADAConfig** and icon ADAConfig on Desktop. To make the configuration, connect converter to computer (see pt. 3.2) and power supply. If after power, on the front panel is not lit green LED PWR, check the power connection (polarity). If the PWR LED lights, set the section of SW1 switch to configuration mode as in table below.

SW1-1	SW1-2
ON	OFF

In the configuration mode the yellow LED located by SW1 micro-switch will blink with frequency 1 Hz. Start the ADAConfig Software and make the configuration of transmission parameters for each converter interfaces. First should be set the number of **[COM port] [1]** for communication with the converter, then readout the configuration from ADA-1040PC4 memory, using the button **[Read configuration] [2]** and make the proper changes of each interfaces setting, as below.

[3] setting converter address from side RS485 MODBUS-RTU bus,

In the section **[Converter Address]** select the field **[Enable]** and in the field **[Address]** enter the address of MODBUS-RTU converter, from the scope 1-247.

[4] setting of transmission parameters for the **AquaMatic** (RS232) port,

- baud rate (kbps) : 0.3, 0.6, 1.2, 1.8, 2.4, 4.8, 7.2, 9.6, 14.4, 19.2, 28.8, 38.4, 57.6, 76.8, 115.2, 230.4,
- number of data bites: 5, 6, 7, 8,
- control parity: no control, parity control, control of none parity,
- number of stop bits : 1, 2,
- frame spacing – range from 1 to 255 (time silence as frame's end),

[5] setting transmission parameters for the **MODBUS-RTU** (RS-485/RS-422) port,

- baud rate (kbps) : 0.3, 0.6, 1.2, 1.8, 2.4, 4.8, 7.2, 9.6, 14.4, 19.2, 28.8, 38.4, 57.6, 76.8, 115.2, 230.4,
- number of data bites: 5, 6, 7, 8,
- control parity: no control, parity control, control of none parity,
- number of stop bits : 1, 2,
- frame spacing – range from 1 to 255 (time silence as frame's end),

After configuration, the setting should be saved on converter memory by using button **[Write configuration] [6]**. Return to work in run mode is made by using SW1 switch as below.

SW1-1	SW1-2
OFF	OFF

The yellow LED (located near the SW1) will turn off in the RUN mode.

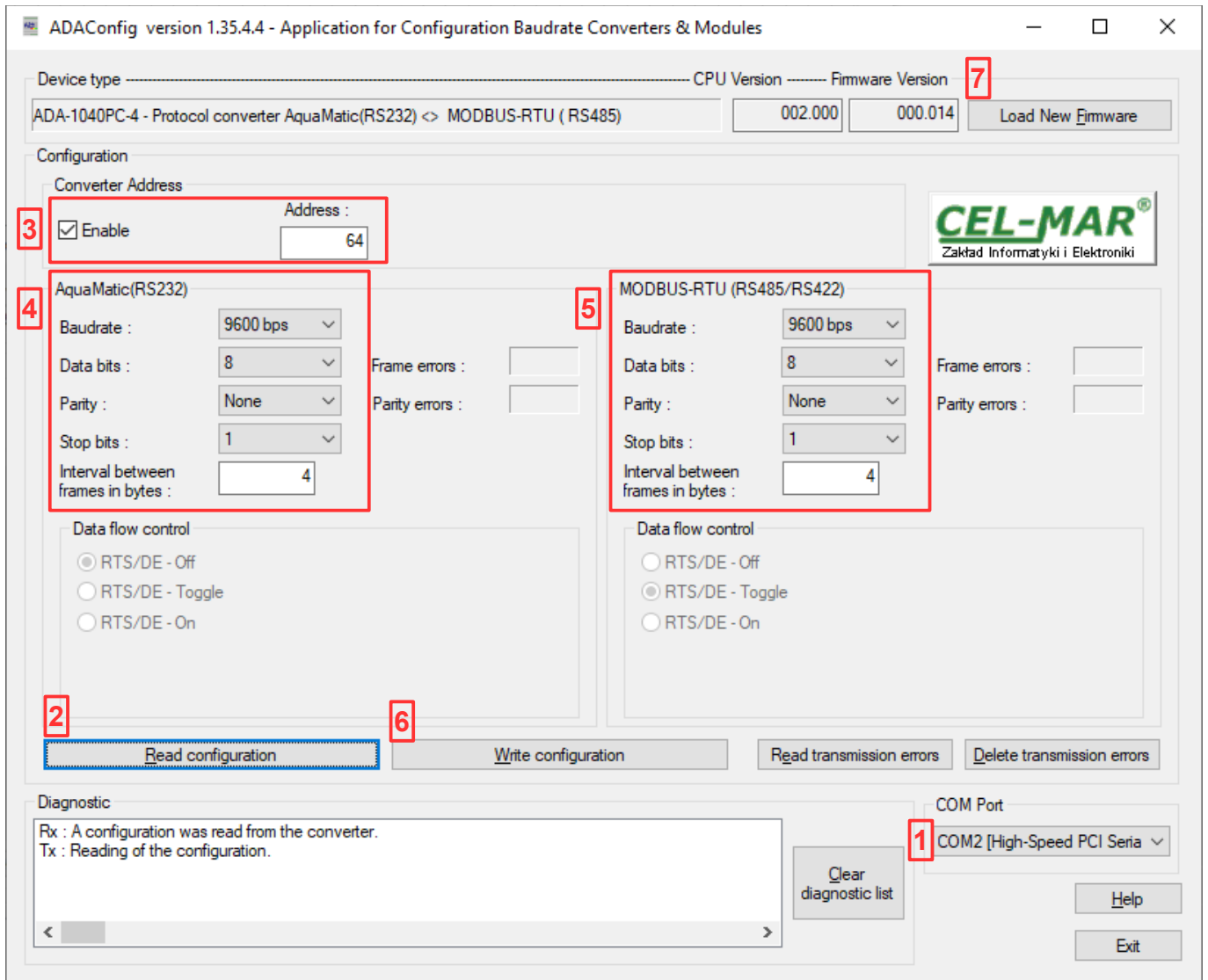

Fig.9. View of ADAConfig software interface.

5.3. FIRMWARE UPDATE

Set SW1 micro switch to configuration mode as in table below.

SW1-1	SW1-2
ON	OFF

In the configuration mode the yellow LED will blink with frequency 1Hz. Press a button **[Load New Firmware]** to change the software delivered by manufacturer. The Select File window will open (fig. below) and select the *.bin file then click **[Open]** - software will be load to *ADAConfig* buffer storage and will be checked. If the *ADAConfig* not detect errors in loaded file, change converter software. Process of updating is visualized by *ADAConfig* in use Progress Window and after proper changing confirmed by correct message.

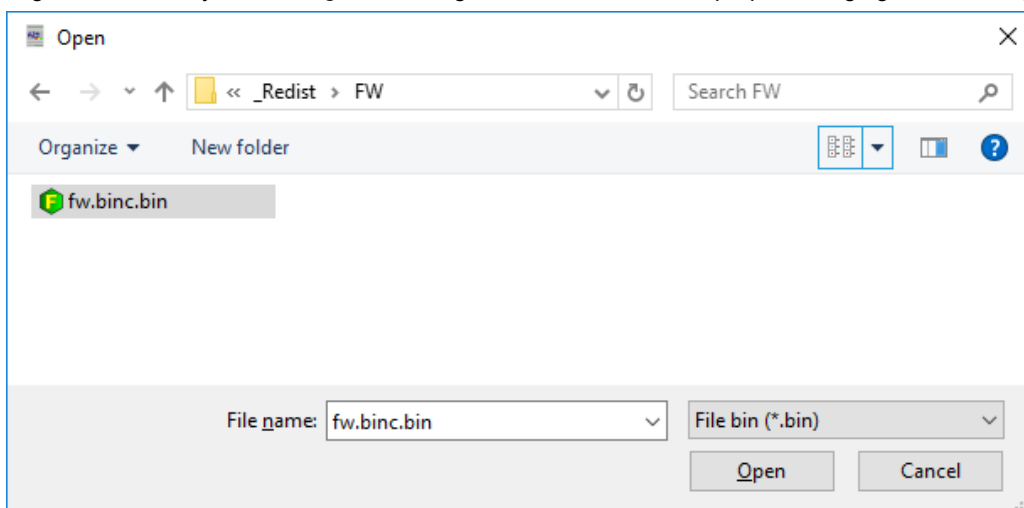

Fig. 10. Selection of firmware file.

During loading software the yellow LED located beside SW1 micro-switch will blink, showing data flow to the converter. If the software was loaded correctly yellow LED will be blink again with frequency 1 Hz. After that, set microswitch SW1 to run mode as shown in the table below.

SW1-1	SW1-2
OFF	OFF

In the run mode the yellow LED (located near the SW1), will turn off.

5.4. EMERGENCY FIRMWARE UPDATE

In case of the unsuccessful update of the converter software, try again according to description in the above point. If the update is still incorrect use emergency firmware update. Set SW1 microswitch mode as in the table below.

SW1-1	SW1-2
ON	ON

After microswitch setting, should be restarted the ADA-1040PC4, by turning OFF and then ON the power supply. The yellow LED will light continuously and the converter will be in Emergency Firmware Update mode. Now follow the description in the above point. After successful software update, set microswitch SW1 to the run mode as shown in the table below.

SW1-1	SW1-2
OFF	OFF

In the run mode the yellow LED (located near the SW1), will turn off.

5.5. FACTORY DEFAULT

In case of faulty functioning the ADA-1040PC4, can be restored the factory default setting of the converter internal registers. Set SW1 microswitch mode as in the table below.

SW1-1	SW1-2
OFF	ON

Disconnect the power and after while **connect** again the power. After that, will be loaded the factory default setting to the converter internal registers.

After this operation, the converter parameters should be set again for operating in the application. Set micro switch SW1 to run mode as shown in the table below.

SW1-1	SW1-2
OFF	OFF

The yellow LED (located near the SW1) will turn off in the RUN mode.

Factory default

<i>Parameter</i>	RS232 AquaMatic	RS485/RS422 MODBUS
Converter Address - Enable	----	ON
Converter Address - Address	----	64
Baud rate	9600bps	9600bps
Data bits	8	8
Parity	Non	Non
Stop bits	1	1
Interval between frames in bytes	4	4
Data flow control	RTS - OFF	DE - Toggle

6. DATA TRANSMISSION DIAGNOSTICS

To readout diagnostics, the SW1 microswitch should be set to the configuration mode.

SW1-1	SW1-2
ON	OFF

In the configuration mode the yellow LED will blink with frequency 1Hz.

Correctness of transmission proceed on RS232 and RS485 interfaces can be checked by readout the errors list by *ADAConfig* Software from the converter memory. Frames error counter will be increased, in case of: improper speed set compared to real speed of data transmission. Parity error counter will be count the errors which can arise in case of misrepresent bytes in transmitted sign. This counter will not work in case of disable control parity

To check those counters press the button **[Read transmission errors]**, and to delete (zeroing of counters in the memory of the converter) press **[Delete transmission errors]**. In case of parity errors or frame errors, should be checked the ADA-1040PC4 converter's configuration and correctness connection of RS485 bus and RS232 device to converter ports.

After finishing the diagnostics, the SW1 microswitch should be set to the run mode as shown in the table below.

SW1-1	SW1-2
OFF	OFF

In the run mode the yellow LED (located near the SW1), will turn off.

7. OPERATION

The ADA-1040PC4 is bidirectional protocol converter of AquaMatic/SP100 to MODBUS-RTU protocol, **with possibility of conversion a baud rate, a data format (number of data bits, parity bit, stop bits)**. Additionally, is a separator of RS232 (AquaMatic) port from RS485/422 (MODBUS-RTU) port.

If to RS-232 port is connected the RCU AquaMatic Industrial, the RS485 MODBUS-RTU bus should be connected to the RS-485/RS-422 port.

Frames of MODBUS protocol having the CRC errors are rejected by the converter.

Frames of AquaMatic/SP100 protocol having errors are also rejected by the converter.

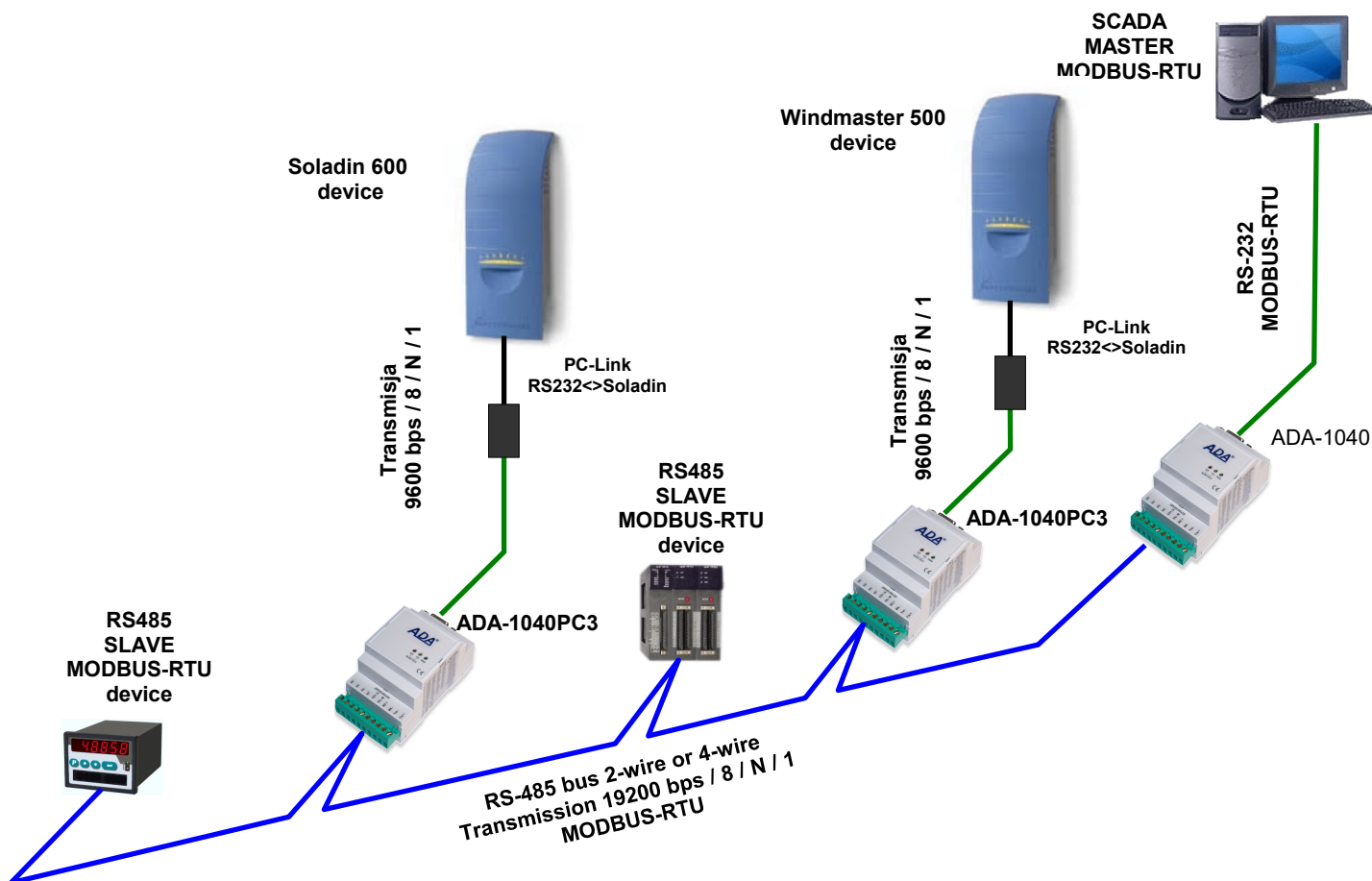

Fig. 11. Connection of RCU AquaMatic Industrial to RS485 MODBUS-RTU bus.

8. IMPLEMENTATION OF MODBUS-RTU PROTOCOL

The ADA-1040PC4 protocol converter allows connecting RCU AquaMatic Industrial as SLAVE to RS485 MODBUS-RTU bus. The length of RS485 bus can be extended by the use of ADA-4040 repeaters or ADA-4044H HUBs RS485.

The MODBUS-RTU protocol used for communication between ADA-1040PC4 converters and SCADA-type system or PLC controller enable easy integration of RCU AquaMatic Industrial in existing automation systems BMS.

8.1. TABLE OF MODBUS-RTU ADDRESSES

8.1.1. REGISTERS ACTUAL VALUE RCU AQUAMATIC INDUSTRIAL PARAMETERS, READOUT BY FUNCTION 04 (3X – REFERENCES) INPUT REGISTERS

Address 3X	Address F4	Parameters description	Attribute	Value	Scale DW
30001	0	Level of cistern in [%]	R	0-100	1
30002	1	Pressure sensor in [bar]	R	0-65535	10
30003	2	Mode of using rainwater: 0=Manual, 1=Automatic	R	0/1	1
30004	3	Overflow REED4 switch (110%)	R	0/1	1
30005	4	REED1 switch (30%)	R	0/1	1
30006	5	REED2 switch (50%)	R	0/1	1

Address 3X	Address F4	Parameters description	Attribute	Value	Scale DW
30007	6	REED3 switch (100%)	R	0/1	1
30008	7	Pump 1	R	0/1	1
30009	8	Pump 2	R	0/1	1
30010	9	Submerge pump 1	R	0/1	1
30011	10	Submerge pump 2	R	0/1	1
30012	11	Pump 1 fault	R	0/1	1
30013	12	Pump 2 fault	R	0/1	1
30014	13	Submerge pump 1 fault	R	0/1	1
30015	14	Submerge pump 2 fault	R	0/1	1
30016	15	Dry running alarm	R	0/1	1
30017	16	Dry running alarm pump 1	R	0/1	1
30018	17	Dry running alarm pump 2	R	0/1	1
30019	18	External motor overload switch 1	R	0/1	1
30020	19	External motor overload switch 2	R	0/1	1
30021	20	Potential free contact, indicator for all faults	R	0/1	1
30022	21	Mainswater solenoid valve	R	0/1	1
30023	22	Back pressure alarm	R	0/1	1
30024	23	Pressure sensor fault	R	0/1	1
30025	24	Level sensor of cistern fault	R	0/1	1
30026	25	Highest tapping point	R	0-65535	1
30027	26	Calibration of level sensor of cistern	R	0-65535	10
30028	27	Start pressure pump 1 [bar]	R	0-65535	10
30029	28	Stop pressure pump 1 [bar]	R	0-65535	10
30030	29	Start pressure pump 2 [bar]	R	0-65535	10
30031	30	Stop pressure pump 2 [bar]	R	0-65535	10
30032	31	Running time pump 1	R	0-65535	1
30033	32	Running time pump 2	R	0-65535	1
30034	33	Running time submerge pump 1	R	0-65535	1
30035	34	Running time submerge pump 2	R	0-65535	1
30036	35	Interval of time in days to start the replacement of mainswater	R	0-65535	1
30037	36	Period of time in seconds to open solenoid valve to replace mainswater [s]	R	0-65535	1
30038	37	Version of Firmware	R	0-65535	1
30039	38	Serial number of rainwater utilisation system (always 0)	R	0-65535	1

8.1.2. REGISTERS ACTUAL VALUE RCU AQUAMATIC INDUSTRIAL PARAMETERS, READOUT BY FUNCTION 03 (4X – REFERENCES) HOLDING REGISTERS

Address 4X	Address F3	Parameters description	Attribute	Value	Scale DW
40001	0	Level of cistern in [%]	R	0-100	1
40002	1	Pressure sensor in [bar]	R	0-65535	10

Address 4X	Address F3	Parameters description	Attribute	Value	Scale DW
40003	2	Mode of using rainwater: 0=Manual, 1=Automatic	R	0/1	1
40004	3	Overflow REED4 switch (110%)	R	0/1	1
40005	4	REED1 switch (30%)	R	0/1	1
40006	5	REED2 switch (50%)	R	0/1	1
40007	6	REED3 switch (100%)	R	0/1	1
40008	7	Pump 1	R	0/1	1
40009	8	Pump 2	R	0/1	1
40010	9	Submerge pump 1	R	0/1	1
40011	10	Submerge pump 2	R	0/1	1
40012	11	Pump 1 fault	R	0/1	1
40013	12	Pump 2 fault	R	0/1	1
40014	13	Submerge pump 1 fault	R	0/1	1
40015	14	Submerge pump 2 fault	R	0/1	1
40016	15	Dry running alarm	R	0/1	1
40017	16	Dry running alarm pump 1	R	0/1	1
40018	17	Dry running alarm pump 2	R	0/1	1
40019	18	External motor overload switch 1	R	0/1	1
40020	19	External motor overload switch 2	R	0/1	1
40021	20	Potential free contact, indicator for all faults	R	0/1	1
40022	21	Mainswater solenoid valve	R	0/1	1
40023	22	Back pressure alarm	R	0/1	1
40024	23	Pressure sensor fault	R	0/1	1
40025	24	Level sensor of cistern fault	R	0/1	1
40026	25	Highest tapping point	R	0-65535	1
40027	26	Calibration of level sensor of cistern	R	0-65535	10
40028	27	Start pressure pump 1 [bar]	R	0-65535	10
40029	28	Stop pressure pump 1 [bar]	R	0-65535	10
40030	29	Start pressure pump 2 [bar]	R	0-65535	10
40031	30	Stop pressure pump 2 [bar]	R	0-65535	10
40032	31	Running time pump 1	R	0-65535	1
40033	32	Running time pump 2	R	0-65535	1
40034	33	Running time submerge pump 1	R	0-65535	1
40035	34	Running time submerge pump 2	R	0-65535	1
40036	35	Interval of time in days to start the replacement of mainswater	R	0-65535	1
40037	36	Period of time in seconds to open solenoid valve to replace mainswater [s]	R	0-65535	1
40038	37	Version of Firmware	R	0-65535	1
40039	38	Serial number of rainwater utilisation system (always 0)	R	0-65535	1

8.2. FRAME STRUCTURE OF MODBUS-RTU PROTOCOL

<i>Device address (1-byte)</i>	<i>Function (1-byte)</i>	<i>Dane (n-bytes)</i>	<i>CRC-16Lo (1-byte)</i>	<i>CRC-16Hi (1-byte)</i>
--------------------------------	--------------------------	-----------------------	--------------------------	--------------------------

8.3. USED FUNCTIONS OF MODBUS-RTU PROTOCOL

<i>Function code</i>	<i>Description</i>
03 (0x03)	Reading RCU AQUAMATIC INDUSTRIAL parameter values from MODBUS-RTU registers
04 (0x04)	Reading RCU AQUAMATIC INDUSTRIAL parameter values from MODBUS-RTU registers

8.3.1. FUNCTION 0x03 / 0x04 - READING RCU AQUAMATIC INDUSTRIAL PARAMETER VALUES

8.3.1.1. READING OF CURRENT PARAMETER VALUE, STORED IN 16-BIT REGISTER [4X / 3X-REFERENCES]

Function 0x03 / 0x04 are used for reading of parameters values from RCU AquaMatic Industrial. The parameter value is read from MODBUS-RTU register and is presented by a 16-bit register. The registers with parameter value are in the integer format of 16-bit with the sign (in C/C++ short type int).

The actual parameter value is obtained from the read register using the following algorithms, using the appropriate factor value **DW** (table above).

Algorithm 1. Readout register is saved to regular type variable (float) and then divide it by the factor **DW**.

```
// Fragment of code in C language (VS6.0) presenting above algorithm
short int siRegParam;
float fValueParam;
.....
fValueParam = (float)siRegParam;
fValueParam = fValueParam / DW;
```

Algorithm 2. Readout register is saved to regular type variable 16-bit (short int) and then divide by the factor **DW**, received change of the dividing it is a number of the hundredth parts of the parameter value.

```
// Fragment of code in C language (VS6.0) presenting above algorithm
short int siRegParam;
div_t div_ValueParam;
.....
div_ValueParam = div((int)siRegParam, DW)
printf( "Total parameter value = %d\n, hundredth parts of the parameter value = %d\n",
        div_ValueParam .quot, div_ValueParam .rem );
```

Query about Pressure sensor in [bar]

<i>Byte no</i>	<i>Designation</i>	<i>Size</i>	<i>Value [hex]</i>
00	ADA-1040PC4 address	1 Byte	11 [1 to F7]
01	Function code	1 Byte	03 / 04
02	Registry address Hi	1 Byte	00
03	Registry address Lo	1 Byte	01
04	Registry number Hi	1 Byte	00
05	Registry number Lo	1 Byte	01
06	CRC-Lo	1 Byte	---
07	CRC-Hi	1 Byte	---

Example. Query of Pressure sensor in [bar] from register address 40002 / address 30002

11-03-00-01-00-01-CRCLo-CRCHi
11-04-00-01-00-01-CRCLo-CRCHi

Response with Pressure sensor in [bar] value

<i>Byte no</i>	<i>Designation</i>	<i>Size</i>	<i>Value [hex]</i>
00	ADA-1040PC4 address	1-byte	11 [1 to F7]
01	Function code	1-byte	03 / 04
02	Number of data bytes	N-byte	02
03	Dane1-Hi	1-byte	00

Byte no	Designation	Size	Value [hex]
04	Dane1-Lo	1-byte	19
05	CRC-Lo	1-byte	---
06	CRC-Hi	1-byte	---

Example. Reading of Pressure sensor in [bar] from register address 40002 / address 30002

11-03-02-00-19-CRCLo-CRCHi
11-04-02-00-19-CRCLo-CRCHi

In respond Pressure sensor in [bar] is presented as 2-byte with values:
P[bar] = 0x0019 => 25/10 => 2,50 [bar]

Response – in case of exception

Byte no	Designation	Size	Value [hex]
00	ADA-1040PC4 address	1-byte	11 [1 to F7]
01	Function code	1-byte	83 / 84
02	Exception code	1-byte	01 – unknown function 02 – unknown data address 03 – unknown data value 04 – RCU AquaMatic Industrial not respond or is faulty
03	CRC-Lo	1-byte	
04	CRC-Hi	1-byte	

ATTENTION !

TO ADA-1040PC4 CAN BE SENT ALSO MODBUS-RTU QUERY ABOUT ALL OR SELECTED PARAMETERS/REGISTERS OF RCU AQUAMATIC INDUSTRIAL.

9. 9. RS232 INTERFACE – PIN DESCRIPTION OF DB-9F SOCKET

Pin	Signal	Description	ADA-1040PC4
1	(DCD)	Level of receiver signal	Connected with DSR
2	(TxD)	Data transmission from ADA-1040PC4	Transmitter
3	(RxD)	Data receiving via ADA-1040PC4	Receiver
4	(DSR)	Readiness of data receiving/ transmission	Connected with DTR
5	(SG)	Signal ground	GND
6	(DTR)	Readiness of data receiving/ transmission	Connected with DSR
7	(CTS)	Device confirms receiving RTS signal from ADA-1040PC3	Connected with RTS
8	(RTS)	Device reports readiness to receive data	Connected with CTS
9	(RI)	Call rate	Not connected

10. VERSIONS

ADA-1040PC4 -		□	-	□
Version:	Standard	1		
3-way galvanic isolation:	1kVDC			23
	3kVDC			33

Order example:
Product Symbol: **ADA-1040PC4-1-23**
1 – standard version,
23 - 1 kV =, 3-way galvanic isolation,

11. SPECIFICATION

TECHNICAL DATE

Transition Parameters

Interface	RS-232	RS-485/RS-422
Connector	DSUB-9 socket, female	Screw terminal, wire max. Ø 2,5mm ²
Max. line length	15 m	1200 m
Max. number of connected devices	1	32
Transmission line	DB9F/DB9M cable, multicore 9x0,34 shielded (up to 15m)	Twisted cable 1-pair or 2-pair , UTP Nx2x0,5 (24AWG), shield inside large interferences STP Nx2x0,5(24AWG)
Standards	EIA-232, CCITT V.24,	EIA-485, CCITT V.11
Protocol	AquaMatic/SP100	Modbus-RTU
Max. baud rate	230,4 kbps	
Transmission type	Asynchronism full duplex, half duplex.	
Optical signalisation	<ul style="list-style-type: none"> • PWR – green LED power supply, • RX - red LED data receiving from RS485/RS422 interface, • TX - yellow LED data transmission through RS485/RS422 interface. 	

Electrical Parameters

Power requirements	10 - 24 - 30 V DC
Power Cable	Recommended length of power cable - up it is 3m.
Power	< 2 W
Protection from reverse power polarization	YES
Galvanic Isolation	1kVDC or 3kVDC – between power circuit and signal lines RS232 and RS485,
Optoisolation	~3kVDC - between signal line RS485 and RS232.
Electromagnetic compatibility	Resistance it disruptions according it the standard PN-EN 55024. Emission of disruptions according it the standard PN-EN 55022.
Safety requiring	According it the PN-EN 60950 norms.
Environment	Commercial and light industrial.

Environmental Parameters

Operating temperature	-30 ÷ 60 ° C
Humidity	5 ÷ of the 95% - non-condensing
Storage temperature	-40 ÷ 70 ° C

Casing

Dimensions	53 x 90 x 62 mm
Material	PC/ABS
Degree of casing protection	IP40
Degree of terminal protection	IP20
Weight	0.10 kg
According is a standard	DIN EN50022, DIN EN43880
Position during operation	Free
Mounting	Rail mounting according it is DIN35 standard / TS35.

Dear Customer,

Thank you for purchasing **CEL-MAR** company product and we hope that, this user manual helped in connecting and starting the **ADA-1040PC4** protocol converter.

We would also like to inform you that we manufacture one of the largest ranges of serial data transmission devices.

We encourage you to check out our full production offer on our website www.cel-mar.pl

We are waiting for your opinion about the product you purchased.

CEL-MAR sp.j.

Computers Science and Electronic Factory
Ściegiennego 219C Str.
25-116 Kielce, POLAND

Tel.....: +48 41 362-12-46
Tel/fax.....: +48 41 361-07-70
Web.....: <http://www.cel-mar.pl/en>
Office.....: office@cel-mar.pl
Sales department.....: sales@cel-mar.pl
Technical information : support@cel-mar.pl